

# SWING BARS

511-119

ITEM NO.	PART NUMBER	DESCRIPTION	QTY.
1	514-501	Bottom Clamp Half	7
2	545-512	Top Clamp Half	7
3	513-206	Swing Bars	7
4	583-204	Top Rail	1
5	583-522	End Fitting	1
6	513-619	Post 2-7/8" x 11' Long	1
7	503-622	Post 2-3/8" x 9' Long	1
8	196-803	1/2" x 3/4" Socket Set Screw	6
9	126-505	5/16" x 1-1/4" Carriage Bolt	14
10	226-501	5/16" Lock Nut	14
11	316-501	5/16" Flat Washer	14
12	416-400	1/4" Socket Key	1

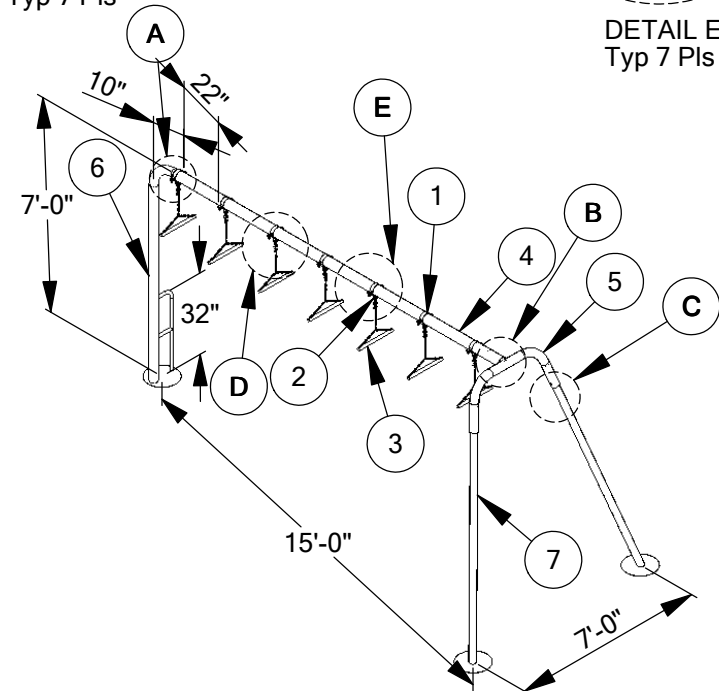
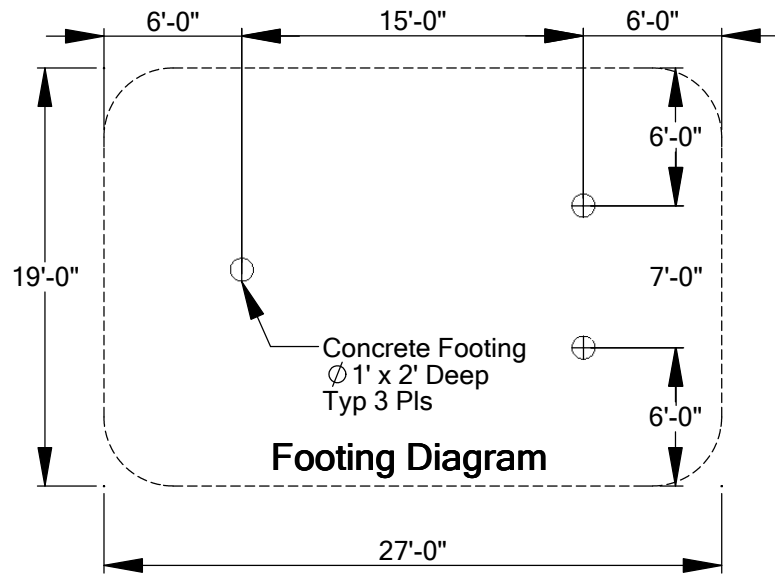
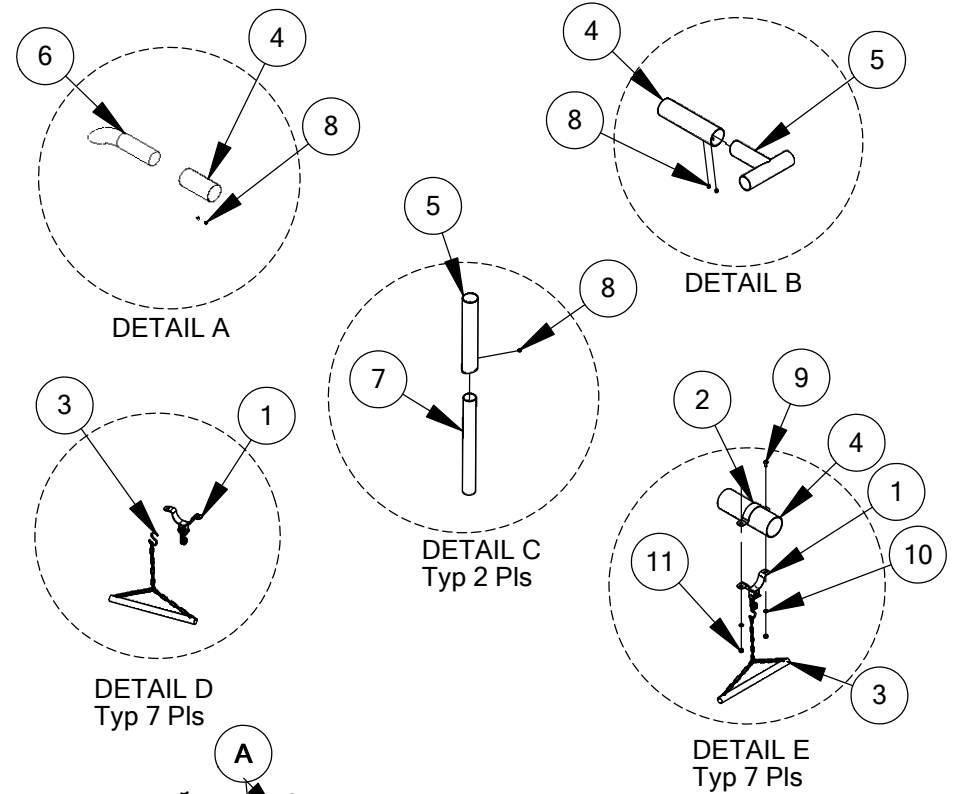

5

4

3

2

1