

① **DETAIL A-A**

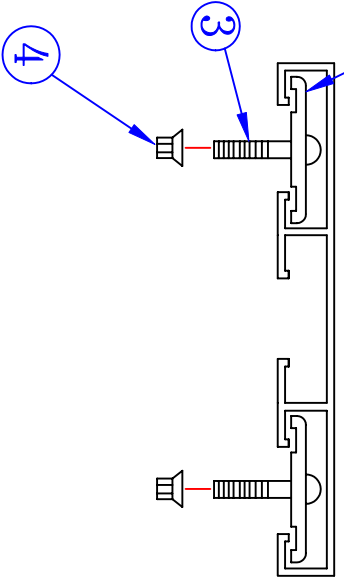

**SEE
DETAIL A-A**

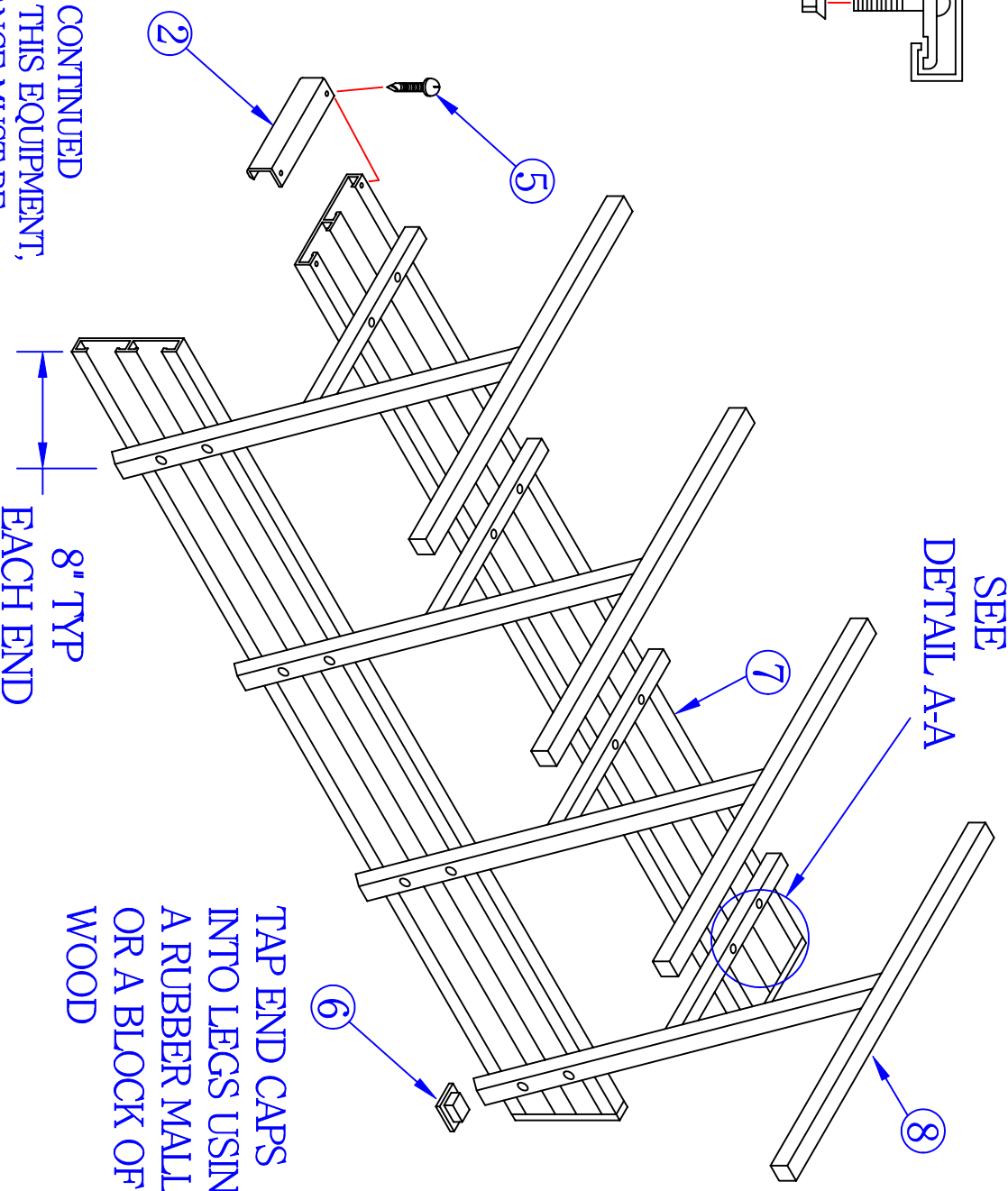

**TAP END CAPS
INTO LEGS USING
A RUBBER MALLET
OR A BLOCK OF
WOOD**

PLEASE NOTE:

**1) FOR SAFE OPERATION AND CONTINUED
HIGH PERFORMANCE FROM THIS EQUIPMENT,
INSPECTION AND MAINTENANCE MUST BE
PERFORMED BEFORE EACH USE**

**2) USE OF THIS EQUIPMENT OTHER THAN
INTENDED, MAY BE HAZARDOUS.**

**3) ALTERATION OR MODIFICATION OF EQUIP-
MENT MAY BE HAZARDOUS. FOR REPAIR OR
REPLACEMENT, PLEASE CALL YOUR DEALER**

JAYPRO SPORTS

21' PLAYER'S BENCH WITH BACK REST, PB-10

LIST OF MATERIALS

<u>PIECE NO.</u>	<u>PART NO.</u>	<u>DESCRIPTION</u>	<u>QTY.</u>
1	AR5044	Bolt Clip With Slot	16
2	AR5045	End Cap	4
3	HB5030	Carriage Bolt 5/16"-18 X 3"	16
4	HN5046	5/16" Flange Nut	16
5	HS5035	#8 Pan Head Screw x 1/2"	8
6	EP0018	2" End Cap	16
7	AR5052	Seat Plank x 21'	2
8	PB801	Leg	4

ASSEMBLY INSTRUCTIONS

TOOLS REQUIRED: Phillips Screwdriver Bit With Electric Drill (1),
1/2" Socket Wrench or Adjustable Wrench (1)

- 1) Slip the end caps (2) snugly onto each end of each plank (7). Using the electric drill, assemble a self-drilling screw (5) through the cap and into the flange of the plank. Two screws are required per end cap. Carefully assemble 2" end caps (6) into bench legs (8).
- 2) For easiest assembly, position seat plank (7) on a level raised surface such as a desk top, bleacher seat or work bench. Place the carriage bolt (3) and bolt clips (1) approximately into place within the slots of the plank. Note that the outside legs should be no more than 8" from the plank edge.
- 3) Position the legs (8) as shown and loosely assemble the hardware illustrated in detail 'A-A'. Do not fully tighten the hardware at this time.
- 4) Stand the unit upright and assemble the backrest plank (7) as illustrated. Level the bench and make sure the legs are adequately spaced apart. Tighten all fasteners fully.