

902-773 HORSE RIDER, 902-774 DINOSAUR RIDER
902-785 BUMBLEBEE RIDER, 902-790 SHARK RIDER
902-791 MOTORCYCLE RIDER

IMPORTANT

PLEASE READ THESE INSTRUCTIONS BEFORE COMMENCING ASSEMBLY. All equipment must be installed in accordance with these instructions. Check your shipment against Bill of Lading and Parts list. Any missing or broken parts must be reported to your distributor within 10 days of receipt of your order. When properly installed and maintained, equipment will give many years of Safe, Trouble-Free use. Periodically check for loose or broken parts. Loose bolts must be tightened and broken parts must be replaced as they can possibly create dangerous situations leading to unnecessary accidents. Resilient Surfacing should be used under all playground equipment. Appropriate publications, available at no charge, from the Consumer Product Safety Commission, include "A Handbook for Public Playground Safety". You can receive your free copy by calling 1-301-504-7908.

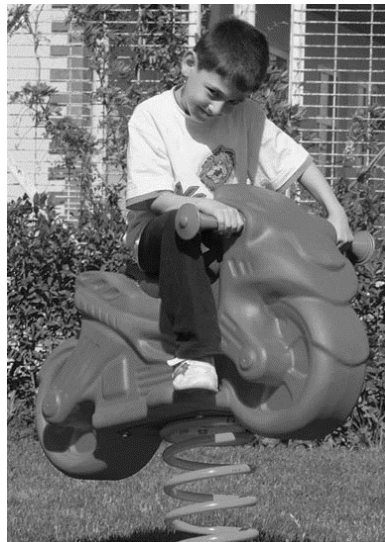

PACKING LIST for 902-773

- 1 CTN - 1 Hardware Bag
- 1 PC - 1 905-773 Horse and Spring Assy.

PACKING LIST for 902-774

- 1 CTN - 1 Hardware Bag
- 1 PC - 1 905-774 Dino and Spring Assy.

Note: Hardware Bag is the same for all Packing Lists

4 -

HARDWARE BAG

Anchor Bolts for Set Concrete

PACKING LIST for 902-785

- 1 CTN - 1 Hardware Bag
- 1 PC - 1 905-785 Bee and Spring Assy.

PACKING LIST for 902-790

- 1 CTN - 1 Hardware Bag
- 1 PC - 1 905-790 Shark and Spring Assy

PACKING LIST for 902-791

- 1 CTN - 1 Hardware Bag
- 1 PC - 1 905-791 Cycle and Spring Assy.

1 CTN	1 PC	2 TOTAL PCS	WT 66#	CLASS 70
-------	------	-------------	--------	----------

902-773 HORSE RIDER, 902-774 DINOSAUR RIDER
902-785 BUMBLEBEE RIDER, 902-790 SHARK RIDER
902-791 MOTORCYCLE RIDER

GENERAL USE/FALL ZONE & FOOTING RECOMMENDATIONS

Stationary & Portable Equipment - Use/Fall Zones should extend a minimum of 6 feet in all directions from the perimeter of the equipment ground space. This area should be covered with the required amount of Resilient Safety Surfacing Material. For Some Equipment - Use/Fall Zones can Overlap. See Consumer Product Safety Commission Guidelines. Diameter and depth of footings illustrated are satisfactory in most applications for pipe sizes up to 2 3/8" diameter. Varying soil & climatic conditions may require deeper and heavier footings in some areas. Check local building codes.

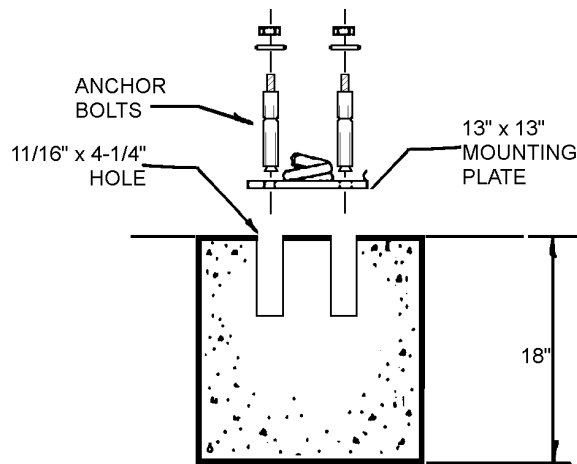

USE AREA & FOOTING LAYOUT

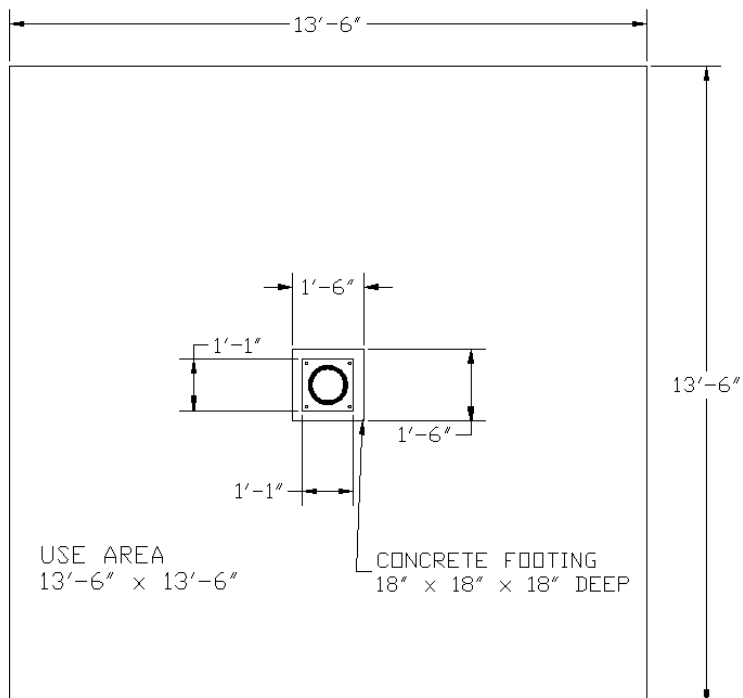

902-773 HORSE RIDER, 902-774 DINOSAUR RIDER
902-785 BUMBLEBEE RIDER, 902-790 SHARK RIDER
902-791 MOTORCYCLE RIDER

Page 3
Rev 08/14/2008

GENERAL ASSEMBLY INSTRUCTIONS:

Check all the parts and hardware with the packing list to be sure you have received everything needed to assemble this product. CONTACT YOUR LOCAL DISTRIBUTOR WITH NOTIFICATION OF ANY MISSING OR DAMAGED PARTS. Contact must be made within ten days of receipt of your order.

Only hand-tighten nuts & bolts on initial assembly. Final tightening should be done EVENLY after final assembly when unit has been plumbed & leveled. After assembly is complete, ANY ENDS OF BOLTS PROTRUDING BEYOND NUTS SHOULD BE CUT OFF AND/OR PEENED OVER TO REMOVE ANY SHARP EDGES. Go over entire unit to file smooth any sharp edges or projections that may have been caused by rough handling in shipping or installation. T-Clamps are designed for both one and two bolt connections. In many situations only one bolt is required. See specific assembly instructions. On products with platforms install 1 - 2 degrees off level to facilitate water drainage.

GENERAL MAINTENANCE INSTRUCTIONS:

Check MONTHLY for loose bolts, damaged or broken parts. Tighten and/or replace immediately.

SPECIFIC ASSEMBLY INSTRUCTIONS:

- STEP #1: Dig footing hole (18" x 18" x18") & fill with concrete. (Approx. 3.5 cubic feet.)
- STEP #2: Let Concrete Cure for at Least 48 hours.
- STEP #3: Using the base of the rider as a guide, mark and drill in the concrete using a drill bit suitable for concrete and of a diameter large enough that the anchor just fits inside (typically 11/16").
- STEP #4: Place anchors in concrete and remove nuts and washers. Place base over exposed bolts and push down. Once rider base is flat, replace nuts and washers and tighten down. Base should not move when finished.
- STEP #5: IMPORTANT: After equipment has been in use for three or four days, all bolts & nuts must be checked and retightened if necessary.