

2 1

B

B

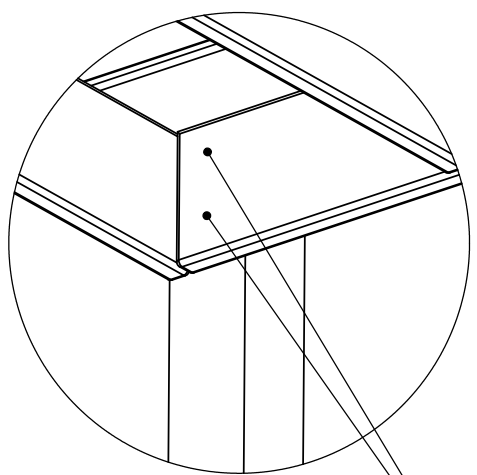
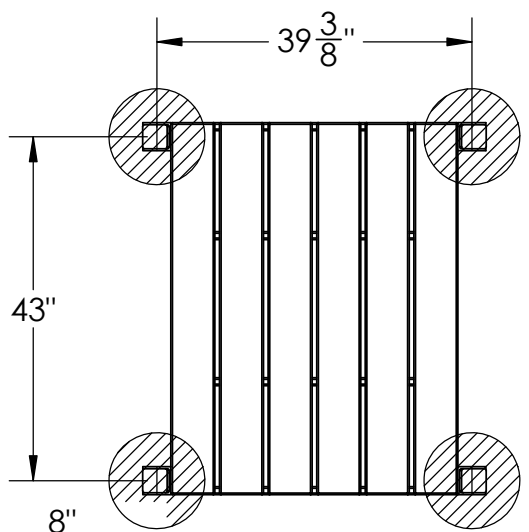

VIEW UNDERNEATH

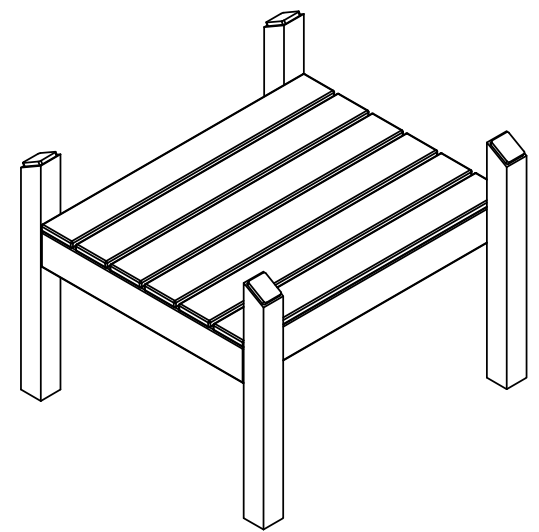

(16" For Large Pause Table)

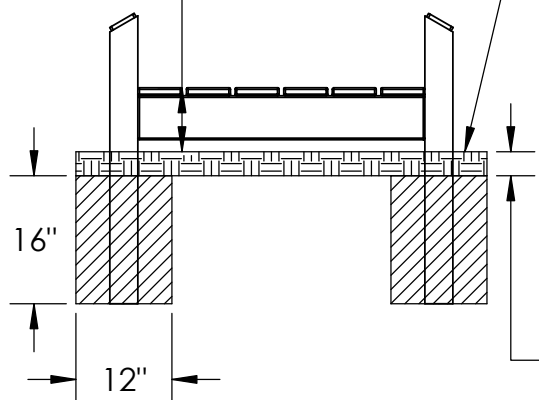

BACKFILL

Approx. 3"

1: Pre-drill with a 1/4" bit through the underside of the platform and into the post.

2: Fasten (x2) 5/16" x 3" Stainless Screw through the deck and into the post, on each corner.

36" Post (x4) (Small Pause Table)
44" Post (x4) (Large Pause Table)

A

A

PROPRIETARY AND CONFIDENTIAL
THE INFORMATION CONTAINED IN THIS DRAWING IS THE SOLE PROPERTY OF PLAYTOPIA INC. ANY REPRODUCTION IN PART OR AS A WHOLE WITHOUT THE WRITTEN PERMISSION OF PLAYTOPIA, INC. IS PROHIBITED.

		UNLESS OTHERWISE SPECIFIED:		NAME	DATE
		DIMENSIONS ARE IN INCHES	DRAWN		
		TOLERANCES:	CHECKED		
		FRACTIONAL ±	ENG APPR.		
		ANGULAR: MACH ± BEND ±	MFG APPR.		
		TWO PLACE DECIMAL ±	Q.A.		
		THREE PLACE DECIMAL ±	COMMENTS:		
		INTERPRET GEOMETRIC TOLERANCING PER:			
		MATERIAL			
		FINISH			
NEXT ASSY	USED ON				
APPLICATION		DO NOT SCALE DRAWING			

Green Paws		
TITLE:		
Small Pause Table (8" Height)		
SIZE	DWG. NO.	REV
A	GP-002	
SCALE: 1:24	WEIGHT:	SHEET 1 OF 1

2

1

2

1

B

B

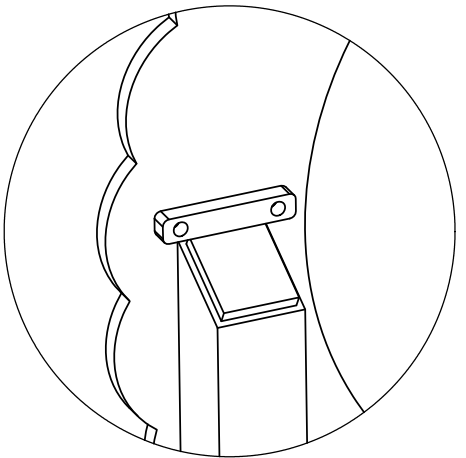
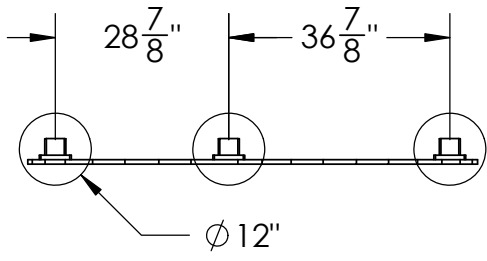

REVERSE VIEW The Double Jump brackets should rest on top of the support posts to ensure the Double Jump is installed level.

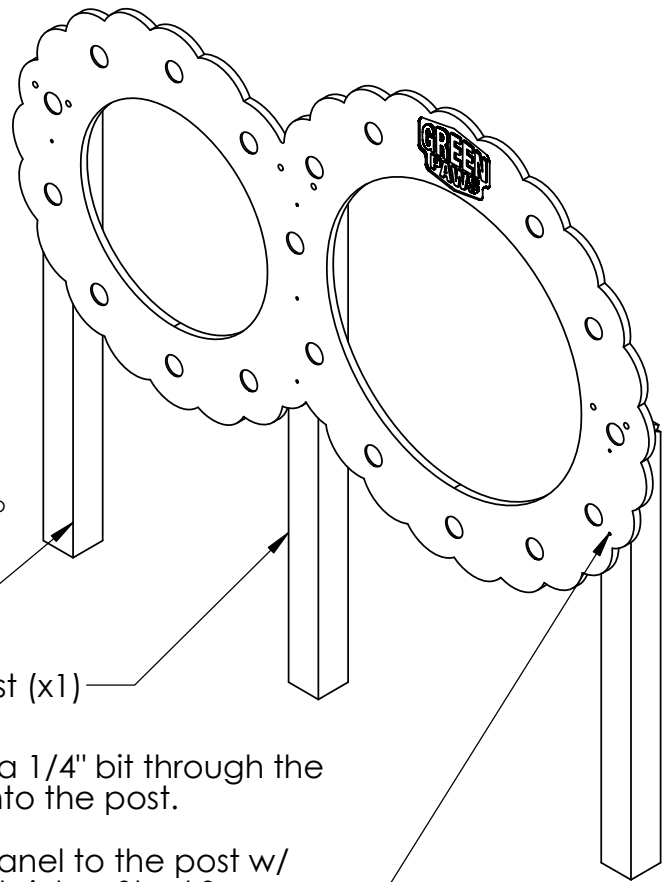

46" Post (x2)

52" Post (x1)

1: Pre-drill with a 1/4" bit through the panel hole & into the post.

2: Fasten the panel to the post w/ (x7) 5/16" x 3" Stainless Steel Screws

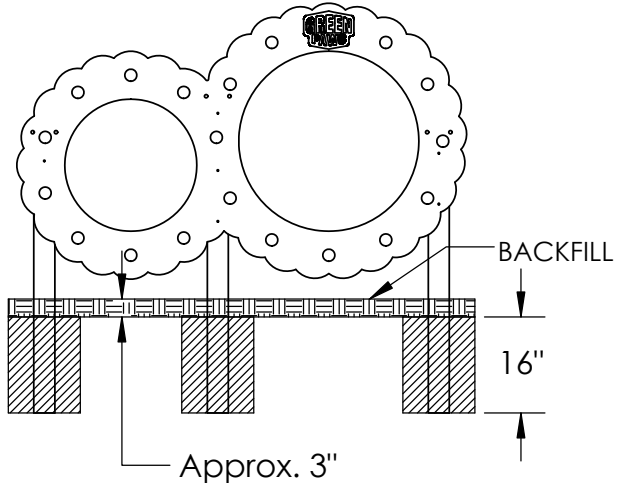

A

A

		UNLESS OTHERWISE SPECIFIED:		NAME	DATE
		DIMENSIONS ARE IN INCHES	DRAWN		
		TOLERANCES:	CHECKED		
		FRACTIONAL ±	ENG APPR.		
		ANGULAR: MACH ± BEND ±	MFG APPR.		
		TWO PLACE DECIMAL ±	Q.A.		
		THREE PLACE DECIMAL ±	COMMENTS:		
		INTERPRET GEOMETRIC TOLERANCING PER:			
		MATERIAL			
		FINISH			
	NEXT ASSY	USED ON			
	APPLICATION				
		DO NOT SCALE DRAWING			

PROPRIETARY AND CONFIDENTIAL
THE INFORMATION CONTAINED IN THIS DRAWING IS THE SOLE PROPERTY OF PLAYTOPIA INC. ANY REPRODUCTION IN PART OR AS A WHOLE WITHOUT THE WRITTEN PERMISSION OF PLAYTOPIA, INC. IS PROHIBITED.

Green Paws

TITLE:
Double Jump

SIZE A	DWG. NO. GP-010	REV
SCALE: 1:32		WEIGHT:
		SHEET 1 OF 1

2

1

2

1

B

B

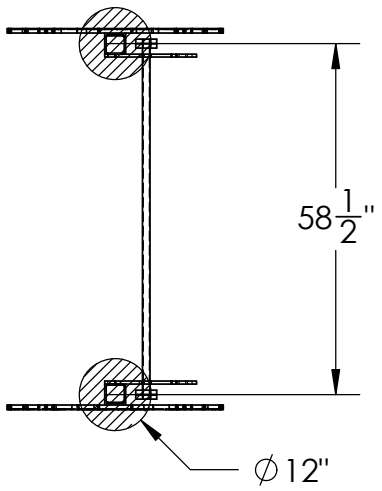

- 1: Pre-drill with a 1/4" bit through the Fire Hydrant and into the post.
- 2: Fasten (x3) 5/16" x 3" Stainless Steel Screws Through the Fire Hydrant & into the post.

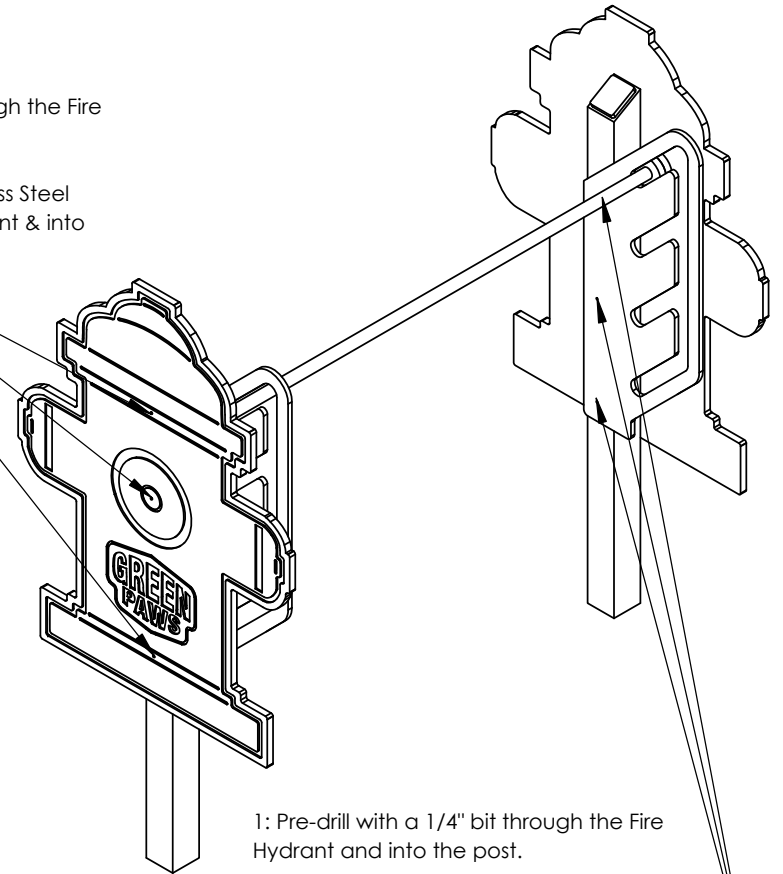

- 1: Pre-drill with a 1/4" bit through the Fire Hydrant and into the post.
- 2: Fasten (x3) 5/16" x 3" Stainless Steel Screws Through the Fire Hydrant & into the post.

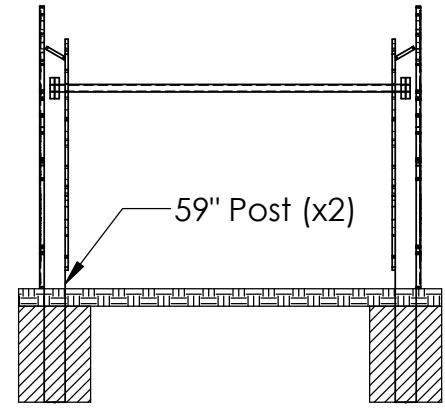
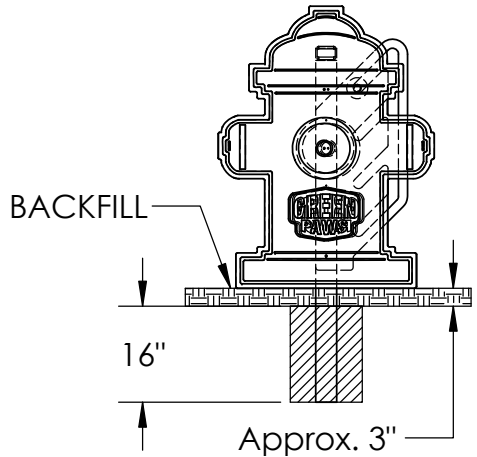

A

A

		UNLESS OTHERWISE SPECIFIED:		NAME	DATE
		DIMENSIONS ARE IN INCHES	DRAWN		
		TOLERANCES:	CHECKED		
		FRACTIONAL ±	ENG APPR.		
		ANGULAR: MACH ± BEND ±	MFG APPR.		
		TWO PLACE DECIMAL ±	Q.A.		
		THREE PLACE DECIMAL ±	COMMENTS:		
		INTERPRET GEOMETRIC TOLERANCING PER:			
		MATERIAL			
		FINISH			
NEXT ASSY	USED ON				
APPLICATION		DO NOT SCALE DRAWING			

PROPRIETARY AND CONFIDENTIAL

THE INFORMATION CONTAINED IN THIS DRAWING IS THE SOLE PROPERTY OF PLAYTOPIA INC. ANY REPRODUCTION IN PART OR AS A WHOLE WITHOUT THE WRITTEN PERMISSION OF PLAYTOPIA, INC. IS PROHIBITED.

Green Paws

TITLE: **Fire Hydrant Leap**

SIZE	DWG. NO.	REV
A	GP-011	
SCALE: 1:32		WEIGHT:
		SHEET 1 OF 1

2

1

2

1

B

B

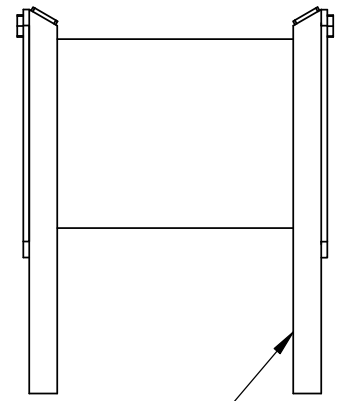
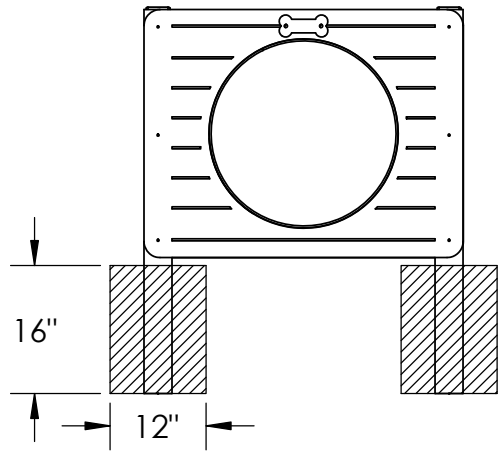

48" Post (x4)

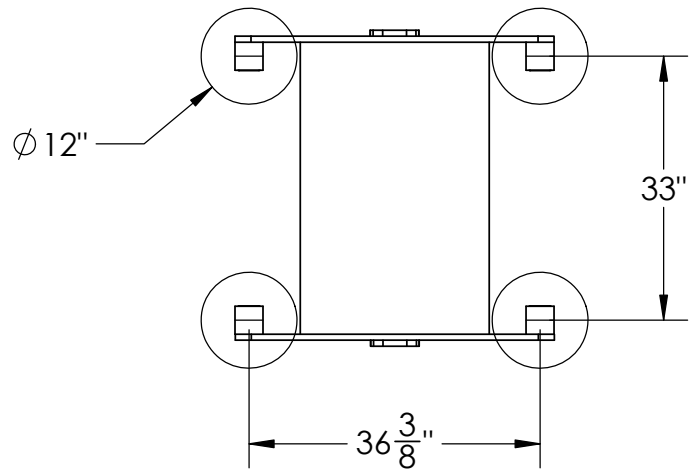
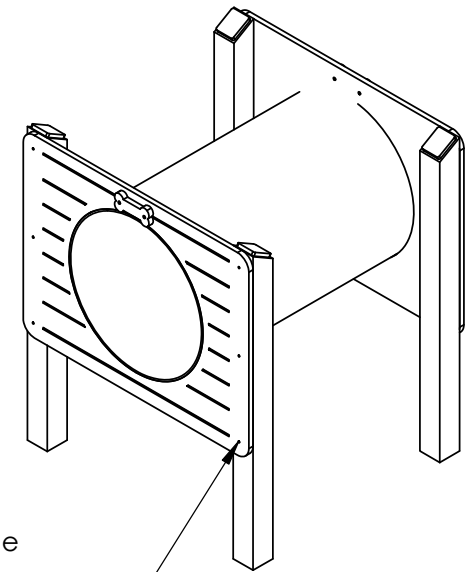

1: Pre-drill with a 1/4" bit through the panel hole & into the post.

2: Fasten the panel to the post w/ (x12) 5/16" x 3" Stainless Steel Screws (6 per panel)

A

A

PROPRIETARY AND CONFIDENTIAL
 THE INFORMATION CONTAINED IN THIS DRAWING IS THE SOLE PROPERTY OF PLAYTOPIA INC. ANY REPRODUCTION IN PART OR AS A WHOLE WITHOUT THE WRITTEN PERMISSION OF PLAYTOPIA, INC. IS PROHIBITED.

		UNLESS OTHERWISE SPECIFIED:		NAME	DATE
		DIMENSIONS ARE IN INCHES	DRAWN		
		TOLERANCES:	CHECKED		
		FRACTIONAL ±	ENG APPR.		
		ANGULAR: MACH ± BEND ±	MFG APPR.		
		TWO PLACE DECIMAL ±	Q.A.		
		THREE PLACE DECIMAL ±	COMMENTS:		
		INTERPRET GEOMETRIC TOLERANCING PER:			
		MATERIAL			
NEXT ASSY	USED ON	FINISH			
APPLICATION		DO NOT SCALE DRAWING			

Green Paws		
TITLE:		
Eco Tunnel		
SIZE	DWG. NO.	REV
A	GP-031	
SCALE: 1:24	WEIGHT:	SHEET 1 OF 1

2

1

2

1

ITEM NO.	PART NUMBER	DESCRIPTION	QTY.
1	Surface Mount Plate	3/4" HDPE PLATE (CNC)	1
2	Surface Mount Post	Recycled Post	1
3	516X4RSSXX	5/16" x 4" GRK RSS Screw	2
4	716X3WEDGE	7/16" x 3" Concrete Wedge Bolt	4

B

B

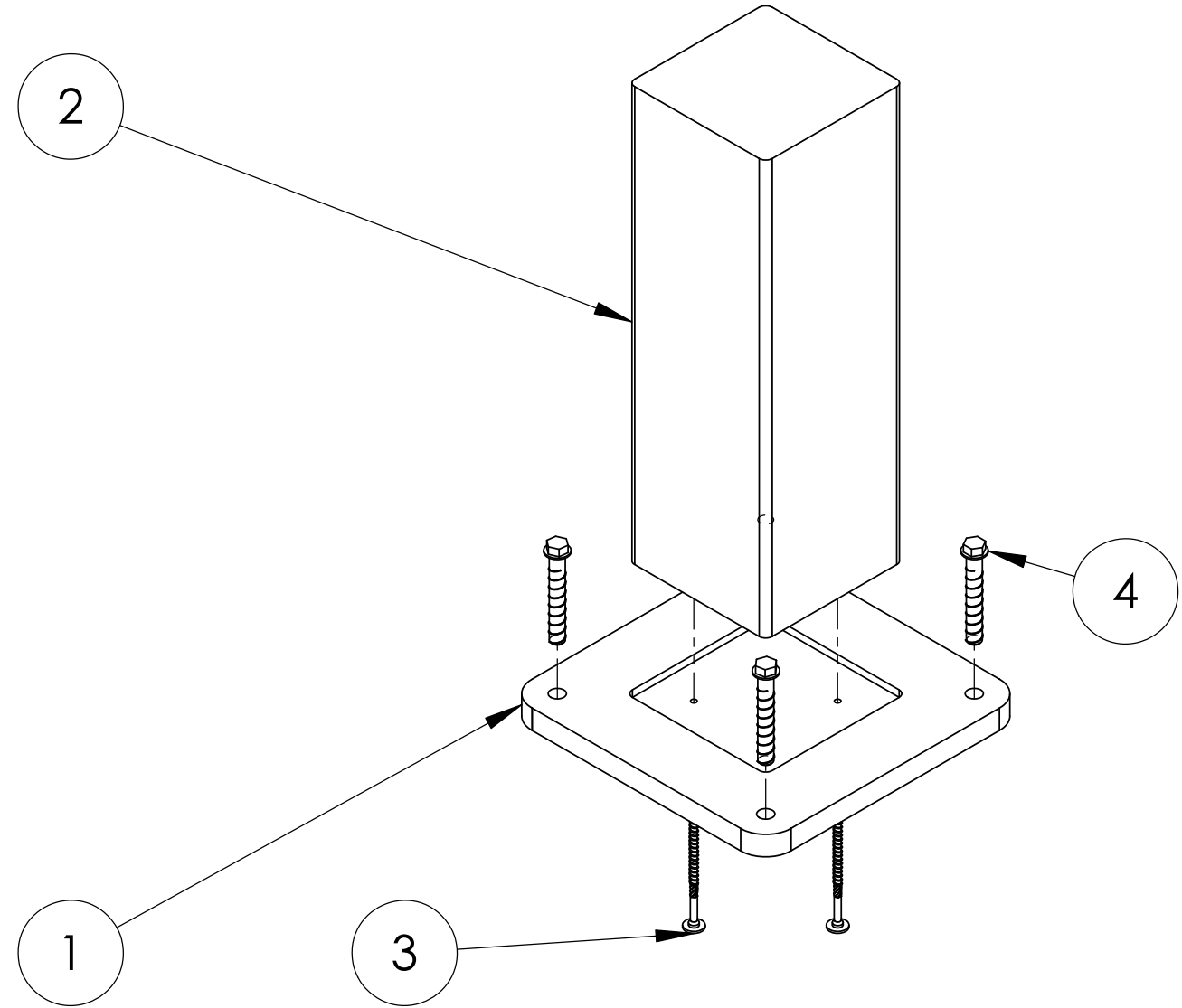
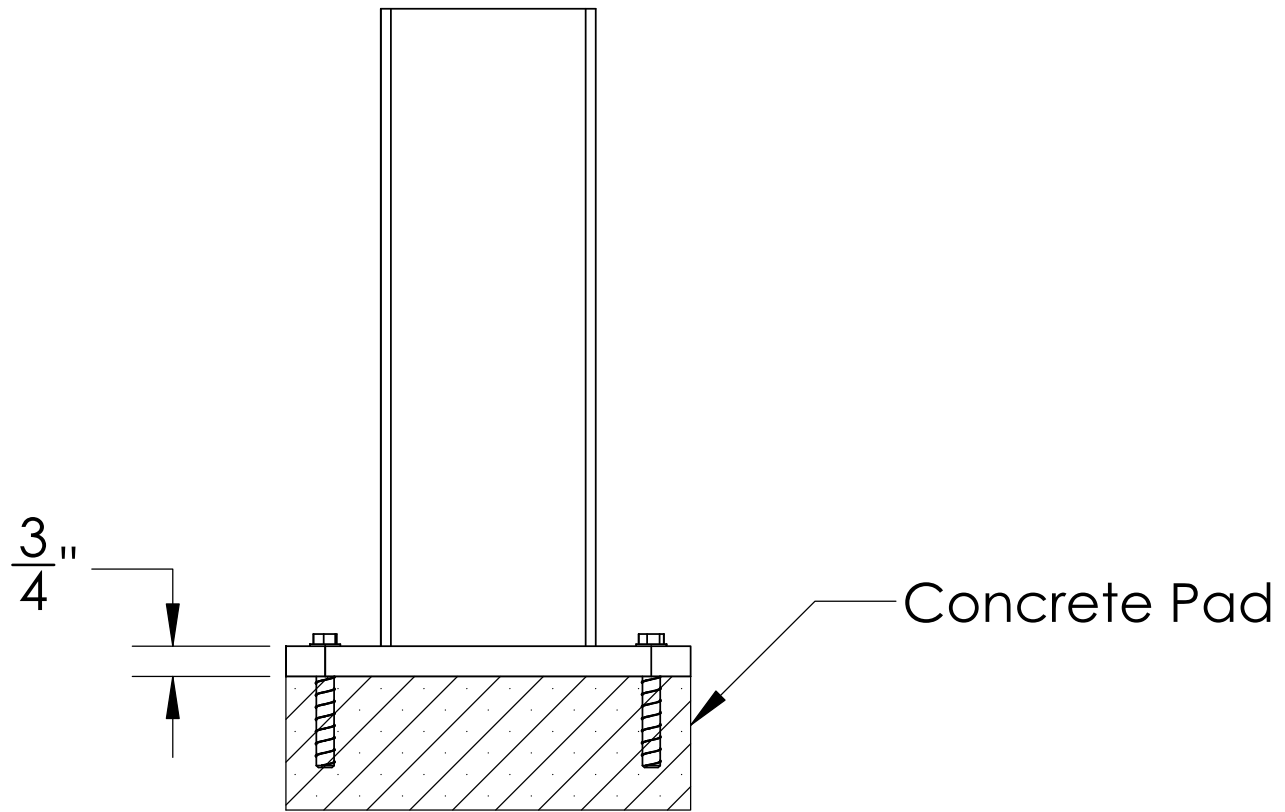
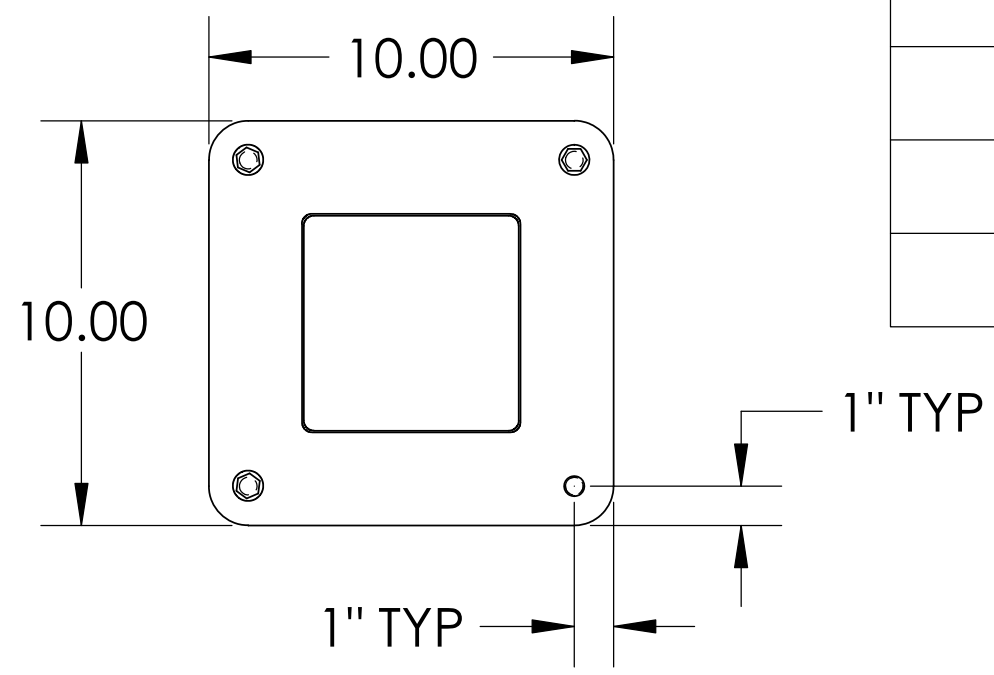

A

A

PROPRIETARY AND CONFIDENTIAL
 THE INFORMATION CONTAINED IN THIS DRAWING IS THE SOLE PROPERTY OF PLAYTOPIA, INC. ANY REPRODUCTION IN PART OR AS A WHOLE WITHOUT THE WRITTEN PERMISSION OF PLAYTOPIA, INC. IS PROHIBITED.

		UNLESS OTHERWISE SPECIFIED:		NAME	DATE
		DIMENSIONS ARE IN INCHES	DRAWN		
		TOLERANCES:	CHECKED		
		FRACTIONAL ±	ENG APPR.		
		ANGULAR: MACH ± BEND ±	MFG APPR.		
		TWO PLACE DECIMAL ±	Q.A.		
		THREE PLACE DECIMAL ±	COMMENTS:		
		INTERPRET GEOMETRIC TOLERANCING PER:			
		MATERIAL			
		FINISH			
NEXT ASSY	USED ON				
APPLICATION		DO NOT SCALE DRAWING			

Green Paws		
TITLE: Optional Surface Mount Plate		
SIZE A	DWG. NO.	REV
SCALE: 1:12	WEIGHT:	SHEET 1 OF 2

2

1

4

3

2

1

B

B

A

A

PROPRIETARY AND CONFIDENTIAL
 THE INFORMATION CONTAINED IN THIS DRAWING IS THE SOLE PROPERTY OF PLAYTOPIA, INC. ANY REPRODUCTION IN PART OR AS A WHOLE WITHOUT THE WRITTEN PERMISSION OF PLAYTOPIA, INC. IS PROHIBITED.

		UNLESS OTHERWISE SPECIFIED: DIMENSIONS ARE IN INCHES TOLERANCES: FRACTIONAL ± 1/32 ANGULAR: MACH ± BEND ± TWO PLACE DECIMAL ± THREE PLACE DECIMAL ±		NAME	DATE	PLAYTOPIA, INC. TITLE: 6X6 Equilateral Deck		
			DRAWN	TM	2/11/15			
			CHECKED	TM	2/11/15			
			ENG APPR.	TM	2/11/15			
		INTERPRET GEOMETRIC TOLERANCING PER:	MFG APPR.	CU	2/13/15			
		MATERIAL Poly Lumber	Q.A.					
NEXT ASSY	USED ON	FINISH	COMMENTS: Surface Mount			SIZE	DWG. NO.	REV
APPLICATION		DO NOT SCALE DRAWING				SCALE: 1:16	WEIGHT: 74 lbs.	SHEET 2 OF 2

4

3

2

1

Surface Mount Plate For Green