

NO.	PART NUMBER	DESCRIPTION	MATERIAL	QTY.
1	35SBFI-SA4	FLAT IRON GRILL ASSEMBLY 3 1/2" PEDESTAL		1
2	35IFP-103G	3 1/2" GRILL PEDESTAL POST	3 1/2" OD. 11 GA ROUND MECH TUBING A-513	1
3	HBOLT 0.3750-16x4x1-N	HEX HEAD BOLT 3/8"-16 x 4"		1
4	LOCKW-3/8	LOCK WASHER 3/8"		1
5	HNUT 0.3750-16-D-N	3/8"-16 HEX NUT		1
6	Concrete Sono Tube	CONCRETE SONO-TUBE FOOTING	3,000 PSI CONCRETE NO FILLERS	1

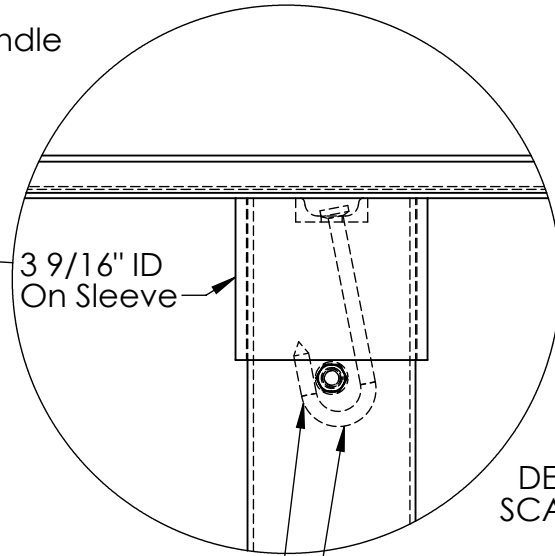

Anti-Theft Locking Bolt

Hook Will Swing So That The Hex Head Bolt Will Go Thru the Eye of the Hook

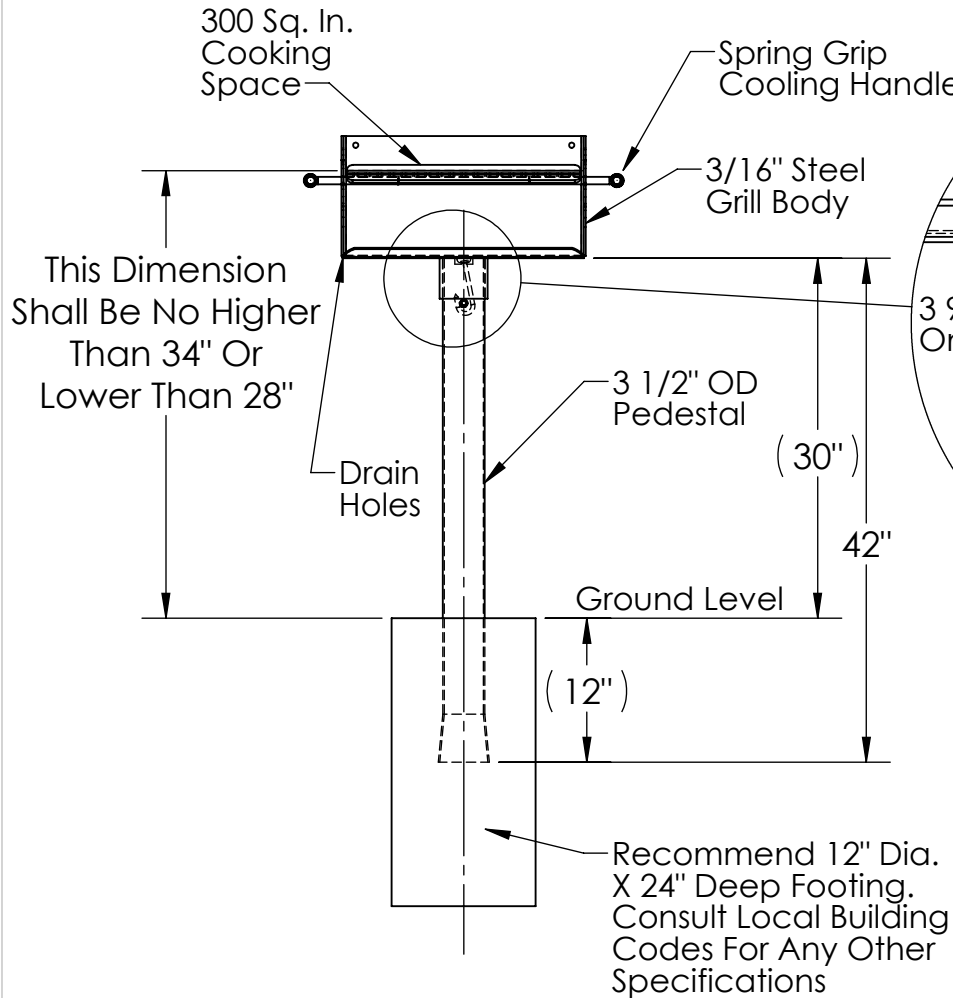
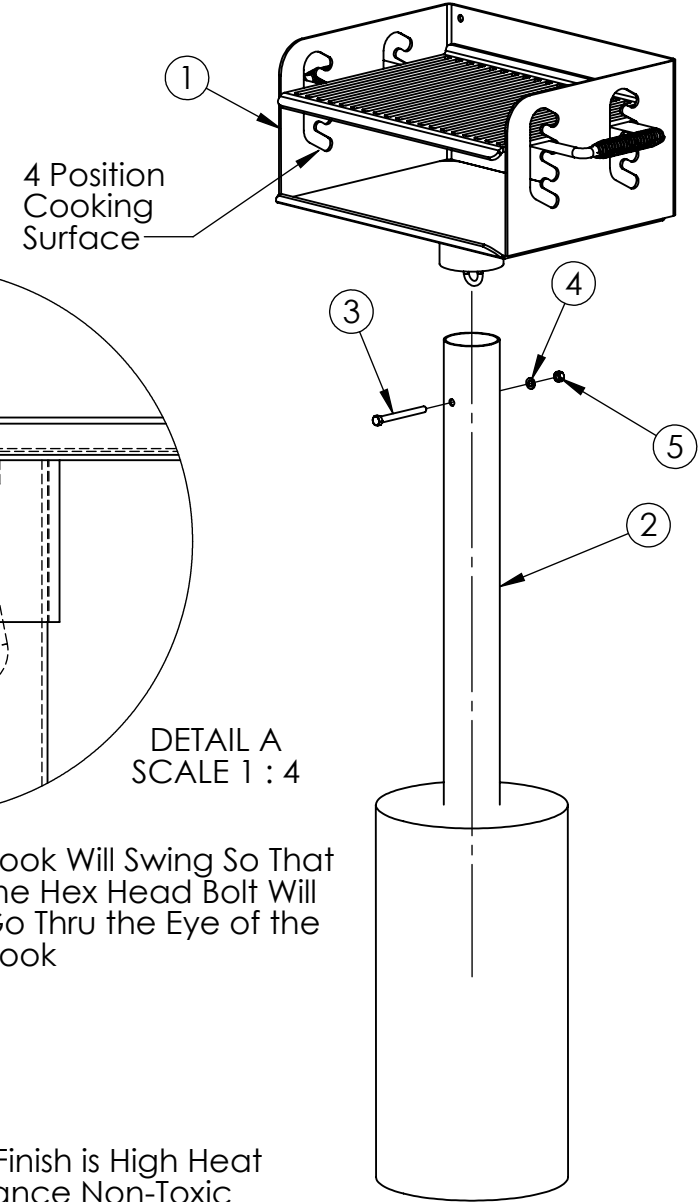

Paint Finish is High Heat Resistance Non-Toxic Enamel

GENERAL NOTES

**WGT:88 LBS.**

DIMENSIONS ARE IN INCHES  
TOLERANCES: LINEAR: ± 1/16  
ANGULAR: ± 1°



SHEET SIZE

**A**

SCALE

**1:24**

REV

CONFIDENTIAL DRAWING.  
INFORMATION IS NOT TO BE COPIED OR  
DISCLOSED TO OTHERS WITHOUT  
CONSENT OF KAY INDUSTRIES.  
SPECIFICATIONS SUBJECT TO CHANGE  
WITHOUT NOTICE.

DRAWN BY

DAT

2/7/2018

DESC:

PEDESTAL GRILL IN GROUND 3 1/2" POST FLAT IRON GRATE

APPROVED

MATL:

Built In House

LAST SAVED

davet

2/8/2018

**PART NO:**