

INSTALLATION INSTRUCTIONS FOR -FRU OPTION

Important: Read all instructions and refer to local codes prior to installation.

Prepare trench for water supply line and waste line (if required) a minimum of 21" below frost line. At fountain location prepare hole to trench depth and large enough for a person to work. Provide 36" centerline of PVC Pipe Casing & FRU valve to fixture location. Lay supply and waste into trench allowing extra length to be trimmed during hook-up.

Depending on code and design requirements, drain may be open, French or sanitary connection. Under drain and PVC Tube Casing opening, place a minimum of five cubic

feet of porous gravel fill. Local soil conditions may require more gravel for drainage.

- It is recommended to include a supply stop appropriately located on the supply line.
- An in-line PRV installed on the supply line is recommended to ensure a working water pressure of 40-60 psi.
- A water filter should be installed on the supply line if sediment or mineral content is a problem.
- A 1/2" NPT swivel elbow supply fitting below PVC Pipe Casing will assist in making up connections to the FRU valve inlet hose.

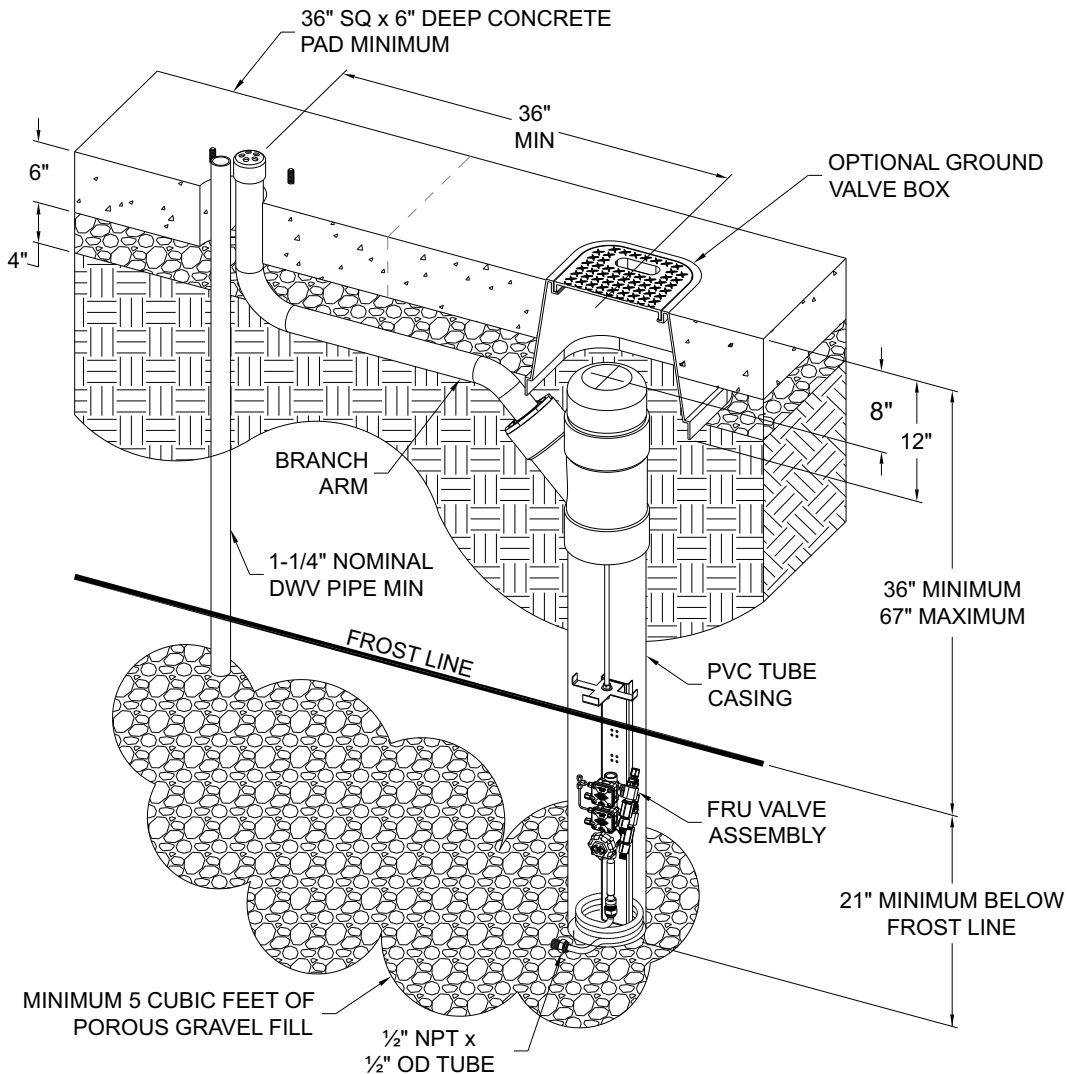

Valve Specifications:
Minimum/Maximum Pressure:
30/100 PSI

Assemble PVC Tube Casing following manufacturer's instructions for primer and glue by others. Do not glue caps. Trim bottom excess of PVC Tube Casing and FRU all-thread lowering rod to allow FRU valve assembly to be lowered a minimum of 21" below frost line. Make up supply connection to loose fixture flexible hose inlet and test for leaks. Pull hose through assembled PVC Tube Casing and connect to FRU.

Position assembled PVC Tube Casing as indicated with Branch Arm orientated toward fixture. Install optional Ground Valve box as required. Refill trench and hole, compacting back fill as required. Leave sufficient depth in hole to accommodate concrete pad (by others).

Prepare the slab area surrounding fountain spreading and compacting gravel as necessary. Prepare forms (refer to fixture installation) to protect Branch Arm and waste stub outs. If required, fix 1/2" UNC L-bolt anchors by others in position arranging L-bolts according to pattern indicated and pour concrete to grade. Leave enough thread for mounting base. Ensure concrete top surface is flat and level. If concrete has cured use appropriate 1/2" concrete anchoring hardware by others following the manufacturer's installation recommendations.

Allow concrete to cure before completing installation.

Position fixture near installation site and thread 1/8" OD Breather tube from FRU valve through Branch Arm, Branch Arm Cap and fixture pedestal and fix to pedestal interior with duct tape by others.

Thread 1/4" OD riser(s) and pushbutton 1/8" OD tubing thru Branch Arm Cap and Branch Arm to make up connections to FRU valve.

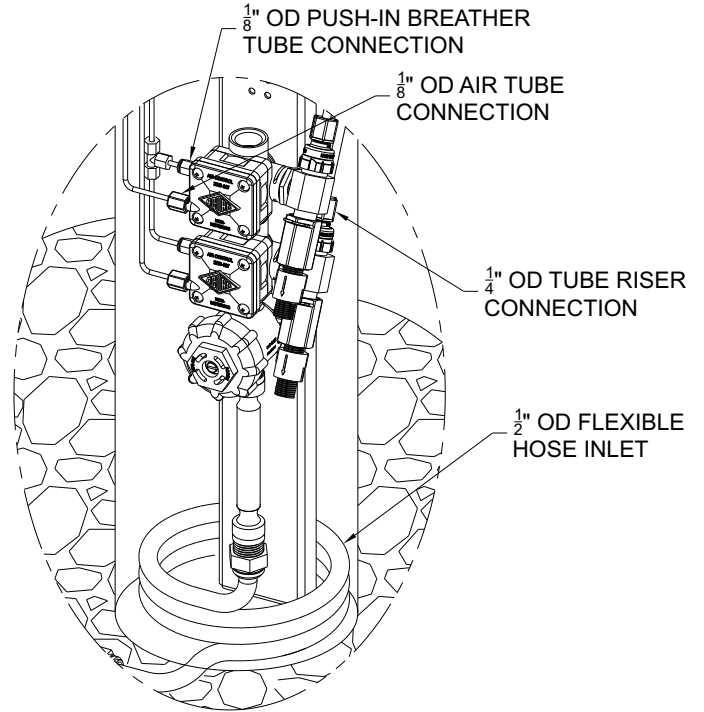

Set fixture into position aligning anchoring studs to pedestal mounting holes. Secure pedestal to slab. After securing fixture in place, make up connections to fixture waste outlet. Refer to fixture installation sheet for additional information.

To ensure plumb installation, lay a bubble level on fountain bowl and adjust using shims or washers until unit is level.

Lower FRU valve assembly into PVC Pipe Casing coiling flexible hose within casing without kinking and seal with cap provided. Conceal and cover with ground valve box lid.

Turn on water supply and test for proper operation and checking for leaks. Ensure water drains out of risers at FRU and into gravel fill when flow stops.

FYI: Protect exposed valve assembly, tubing and tube openings to prevent damage to equipment or to prevent tubes from becoming filled with soil or debris.

Excess tubing should be trimmed to fit. When tubing is properly trimmed, FRU valve may be raised to grade level to allow maintenance or servicing and returned to bottom of casing when completed. Riser tubing should include no low spots where water may collect and freeze.

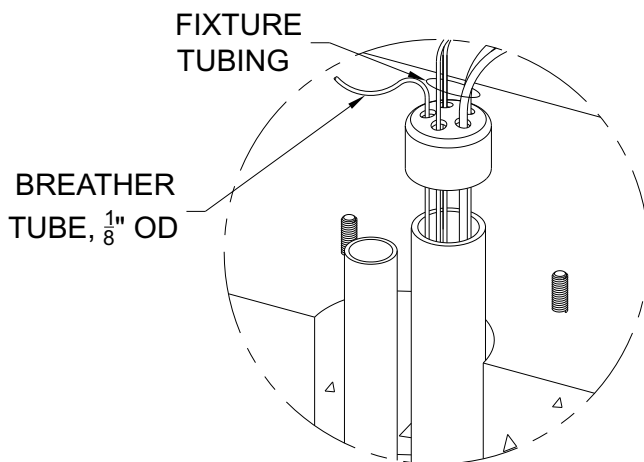

Place insulation material by others in valve casing as shown and replace cap. Place insulation material by others in valve ground box and cover. Install drinking fountain access panels to complete installation.

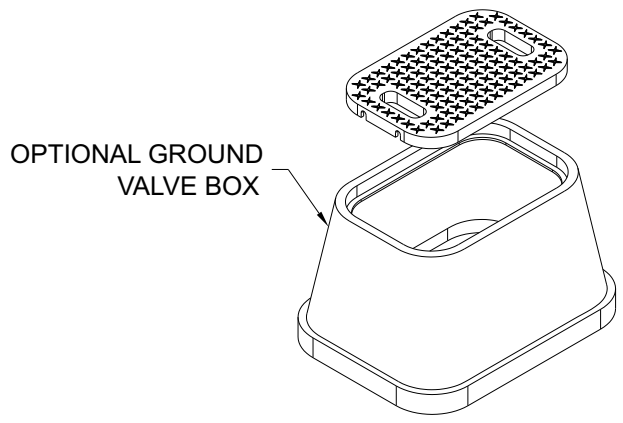
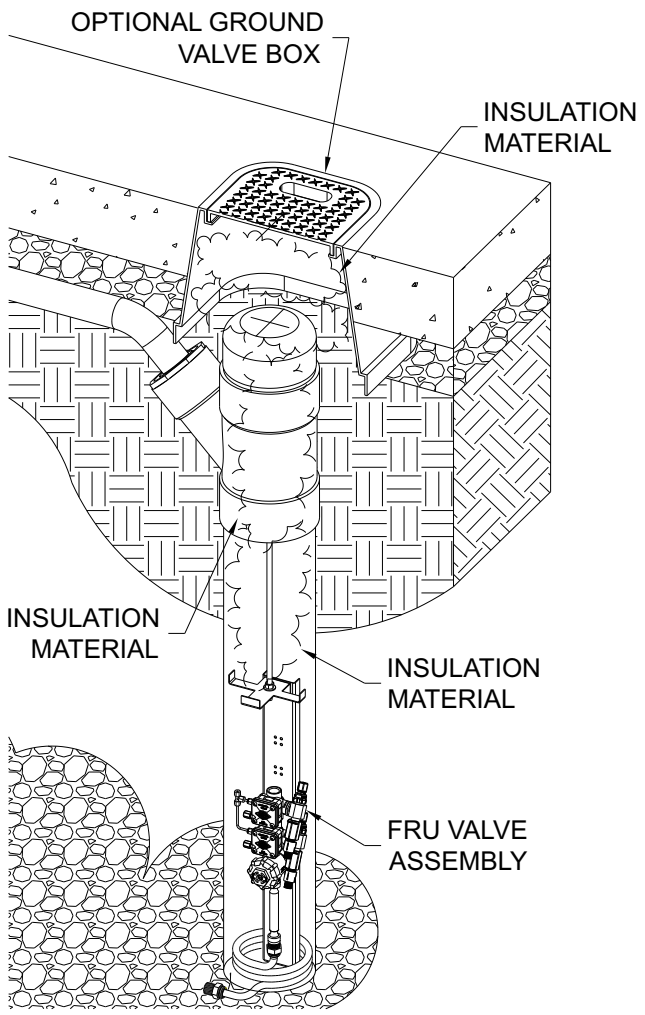
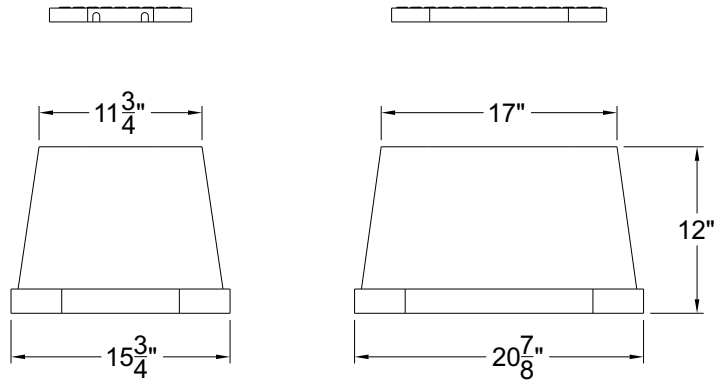

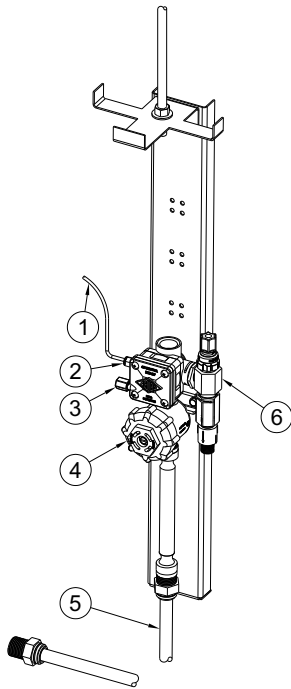

FRU1

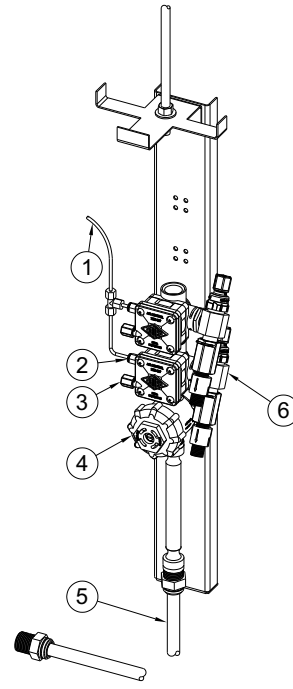

FRU2

- ① 1/8" OD BREATHER TUBE
- ② 1/8" OD PUSH-IN FITTING FOR BREATER TUBE
- ③ 1/8" OD COMPRESSION FOR PUSHBUTTON
- ④ VALVE CHECKSTOP
- ⑤ 1/2" OD x 10 FEET LONG REINFORCED HOSE INLET w/ 1/2" OD x 1/2" NPT FITTING
- ⑥ 1/4" OD COMPRESSION RISER FITTING

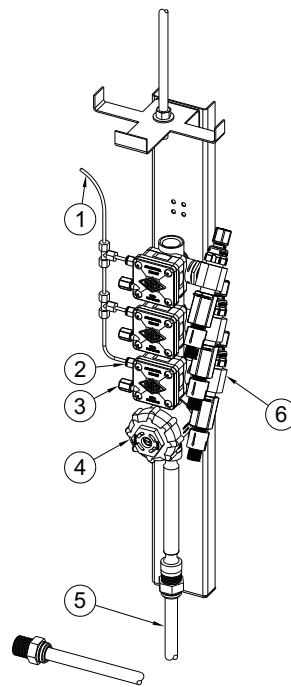

FRU3

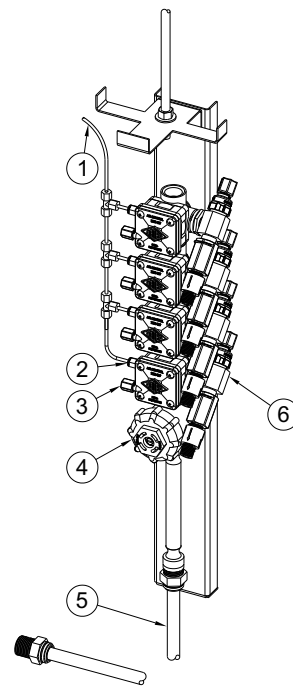

FRU4

Description	Part No.	Diagram
VALVE COMPONENTS		
1/8" OD x 15 Feet Long, Polyethylene Tubing	2150-000-000	
1/4" OD (.040 Wall) x 15 Feet Long, Polyethylene Riser Tubing	2160-000-000	
1/2" OD x 10 Feet Long, Braided Reinforced Supply Inlet	7000-139-199	
1/2" OD x 1/2" NPT Push-in Fitting	7000-140-000	
Riser Check Valve Assembly	7000-115-003	
1/8" OD Tube TEE fitting	1895-400-000	

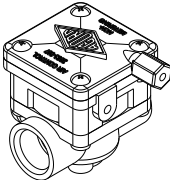
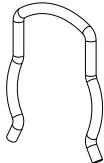
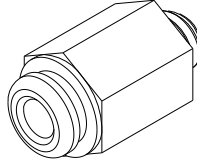
Description	Part No.	Diagram
VALVE COMPONENTS		
Direct Acting Valve Assembly -Open End	2570-100-001	
Retaining Clip, Air-Control Valves	0326-100-000	
1/8" OD x #10-32 UNFE, Push-In Fitting	7000-125-000	

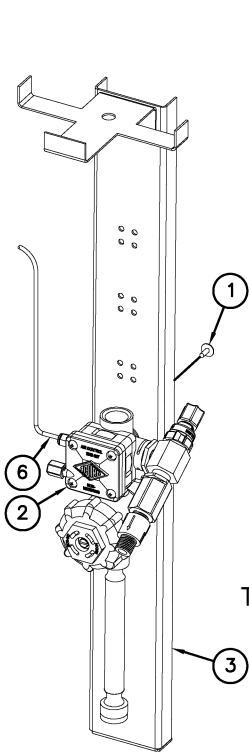

STEP 1

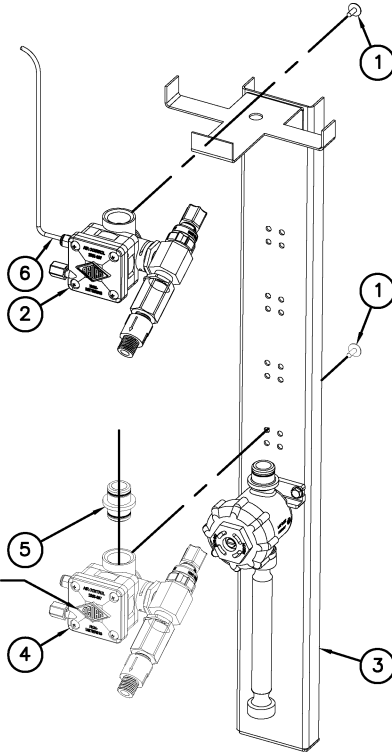

STEP 2

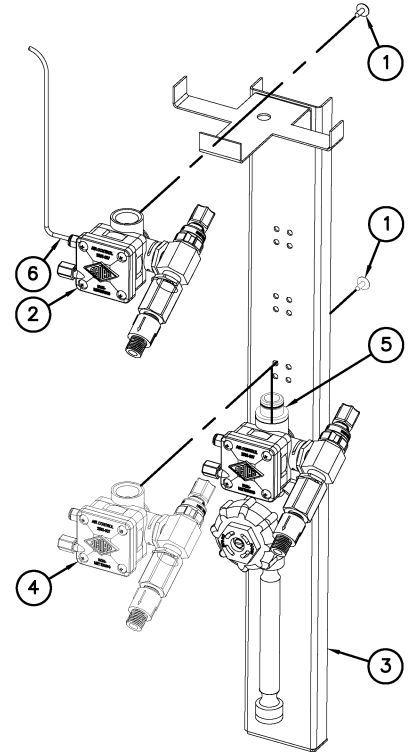

STEP 3

1/8" OD PE AIR TUBING CONNECTION

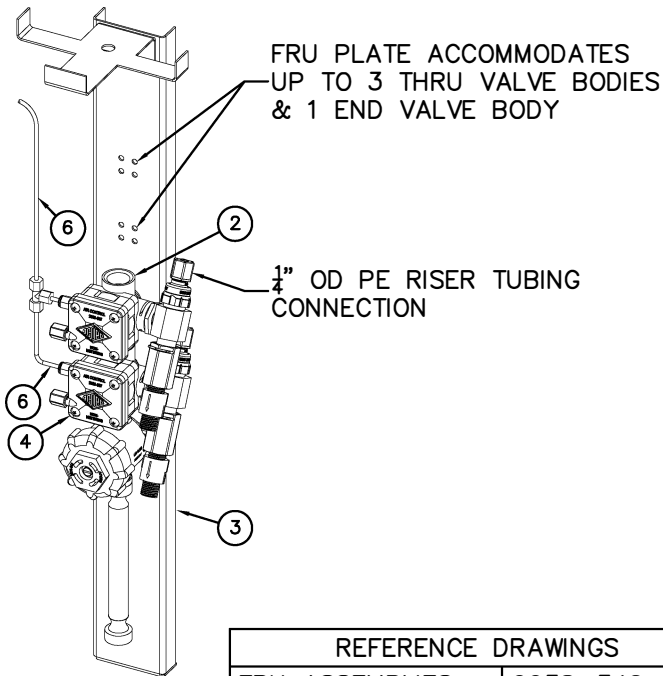

STEP 4

FRU PLATE ACCOMMODATES UP TO 3 THRU VALVE BODIES & 1 END VALVE BODY

1/4" OD PE RISER TUBING CONNECTION

INSTALLATION INSTRUCTIONS:

- A- REMOVE SCREW ① FIXING EXISTING END VALVE BODY ASSEMBLY ② FROM MOUNTING CHANNEL ③ AND SEPARATE VALVE BODY ASSEMBLY FROM REMAINDER OF VALVE MANIFOLD ASSEMBLY AND PLATE.
- B- ADD NEW THRU VALVE BODY ④ TO MOUNTING CHANNEL MAKING UP CONNECTIONS TO CHECKVALVE OR VALVE MANIFOLD ASSEMBLY.
- C- ADD MALE-TO-MALE VALVE O-RING COUPLER ⑤ TO END OF THRU VALVE BODY ④ PRIOR TO MOUNTING END VALVE BODY ② ASSEMBLY TO MOUNTING CHANNEL ③ BY ALIGNING SCREW HOLES ON PLATE WITH BOTTOM VALVE ALIGNMENT PIN AND FIXING WITH SCREW ①.
- D- MAKE UP CONNECTIONS TO BREATHER TUBE MANIFOLD ⑥ WITH ⑦ TEE AND 1/8" OD PE TUBING PROVIDED.
- E- TEST FOR LEAKS.







REFERENCE DRAWINGS	
FRU ASSEMBLIES	9938-340-5M0
FRU PARTS	9938-333-0M1
CHECKSTOP	9956-040-0M3

TITLE FRU VALVE MANIFOLD ADDITION		
		DATE REVISED 09/16/13

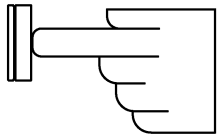
PUSH PAD / PUSH BUTTON FRU FREEZE RESISTANT DRINKING FOUNTAINS
NON-METERING AIR-CONTROLLED VALVE - (DIRECT ACTING)

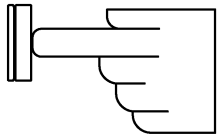
CONDITION:

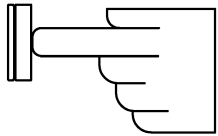
SOLUTION:

<p>NO WATER FLOW:</p>  	<ol style="list-style-type: none"> 1.1 Check water main supply – open. 1.2 Inspect checkstops – open. 1.3 Inspect checkstop strainer for debris – clean. 1.4 Check 1/8” O.D. tubing and fittings for leaks. 1.5 Check pushbutton air diaphragm for holes. 1.6 Check servomotor diaphragm center hole for blockage.
<p>WATER DRIPS / WILL NOT SHUT OFF:</p> 	<ol style="list-style-type: none"> 2.1 Check servomotor diaphragm offset hole for debris. 2.2 Check servomotor seat for build-up or damage. 2.3 Check servomotor seat o-ring for damage. 2.4 Check servomotor plate and diaphragm for obstruction.
<p>REDUCED WATER FLOW:</p>  	<ol style="list-style-type: none"> 3.1 Check water main supply for 20 psig minimum flow pressure. 3.2 Check valve riser tubing for crimping. 3.3 Inspect checkstop strainer for debris – clean. 3.4 Check valve flow control for blockage – clean. 3.5 Inspect bubbler for debris – clean.
<p>PREMATURE WATER SHUTOFF:</p>  	<ol style="list-style-type: none"> 4.1 Check 1/8” O.D. tubing and fittings for leaks. 4.2 Check pushbutton air diaphragm for holes.

Refer to Air-Controlled Valve Maintenance Detail on drawing # 9940-203-0M1 for -FRA_ Above Ground units and on drawing # 9940-204-0M1 for Stone & -FRU_ Below Ground units to locate solutions above.

	TITLE		
	FRU FREEZE RESISTANT FOUNTAIN VALVE MAINTENANCE INSTRUCTIONS		
	MANUFACTURE DATE	DATE ISSUED	DRAWING NUMBER
JANUARY 2006 TO PRESENT	10/25/10	9940-202-0M1	
	DATE REVISED		

**PUSH PAD / PUSH BUTTON FRU BELOW GROUND FREEZE RESISTANT DRINKING FOUNTAINS
NON-METERING AIR-CONTROLLED VALVE - (DIRECT ACTING)**

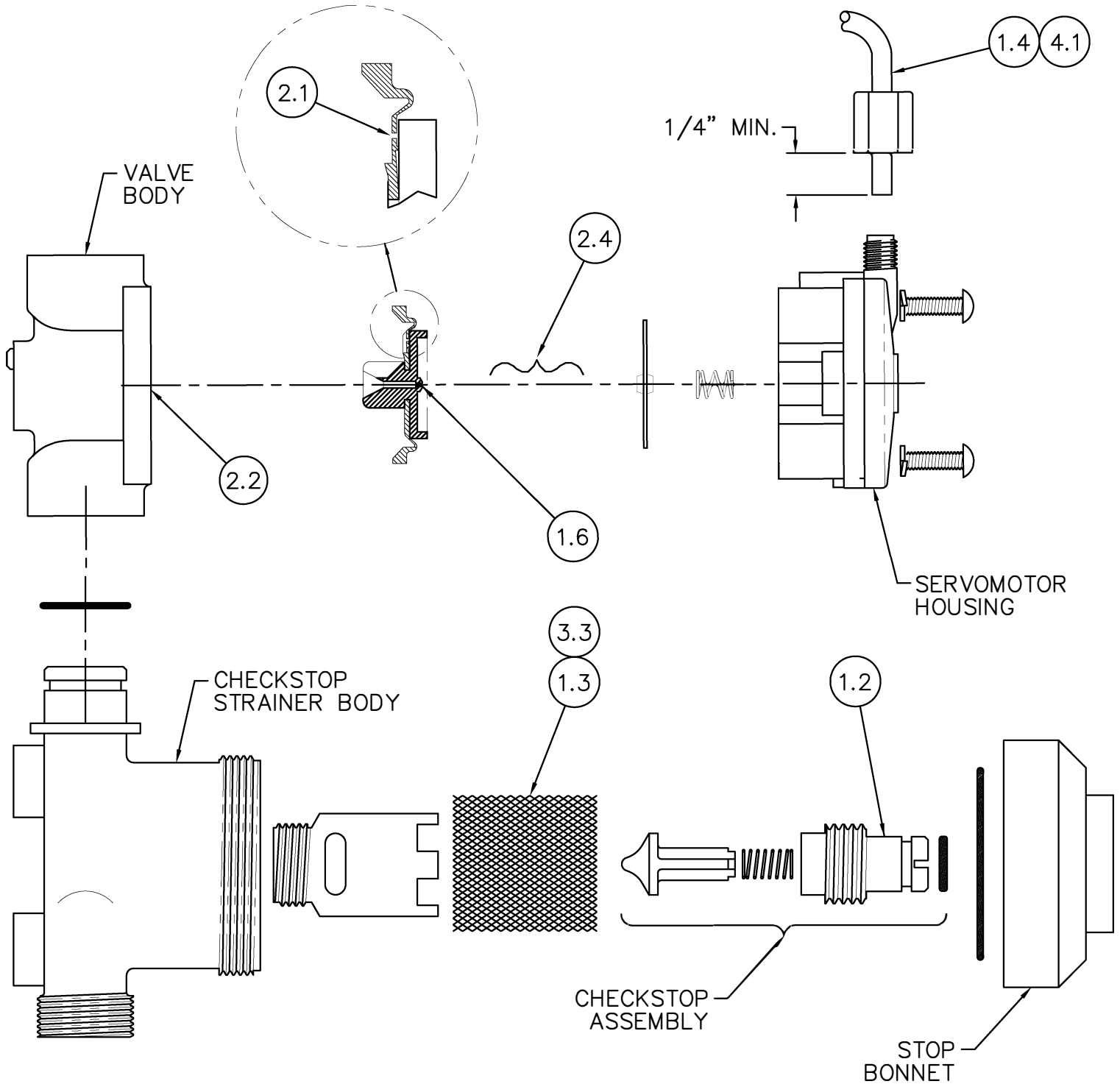

CHECKSTOP STRAINER - SERVOMOTOR DETAIL

Refer to drawing #9940-202-0M1 for Valve Maintenance Instructions numbered solutions detailed above.

<p>TITLE NON-METERING FRU AIR-CONTROLLED VALVE MAINTENANCE INSTRUCTIONS</p>		
<p>MANUFACTURE DATE JANUARY 2006 TO PRESENT</p>	<p>DATE ISSUED 10/25/10</p> <p>DATE REVISED</p>	<p>DRAWING NUMBER 9940-204-0M1</p>