

NO.	PART NUMBER	DESCRIPTION	MATERIAL	QTY.
1	IFP-SAS	ANCHOR SPADE WELD ASSEMBLY		3
2	FR7-SA4	GRILL 7" FINAL WELD ASSY		1
3	HBOLT 0.5000-13x1.5x1.25-N	1/2"-13x 1 1/2" HEX BOLT		3
4	Regular LW 0.5	1/2" REGULAR LOCK WASHER		3
5	HNUT 0.5000-13-D-N	1/2"-13 HEX LOCKNUT		3

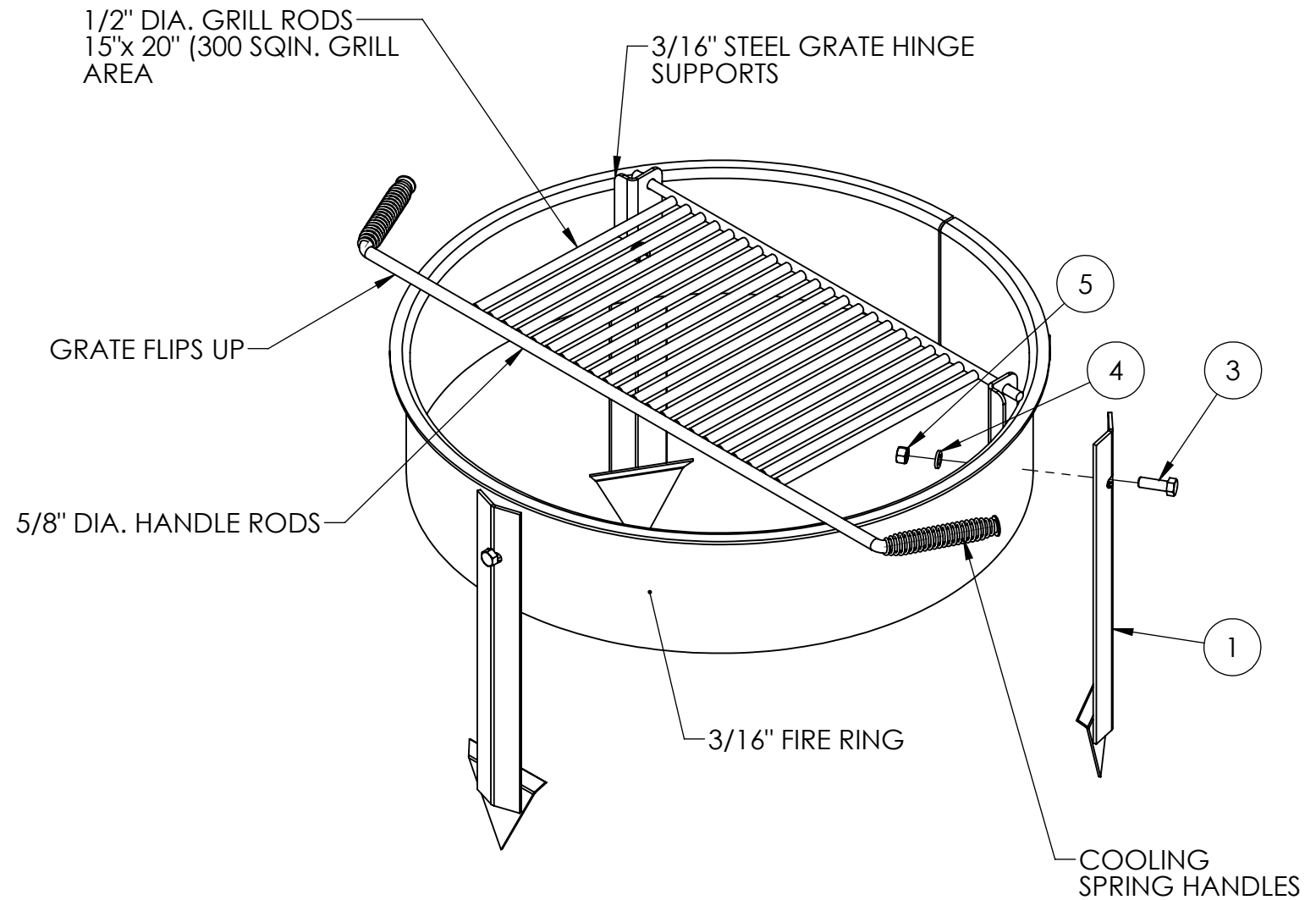
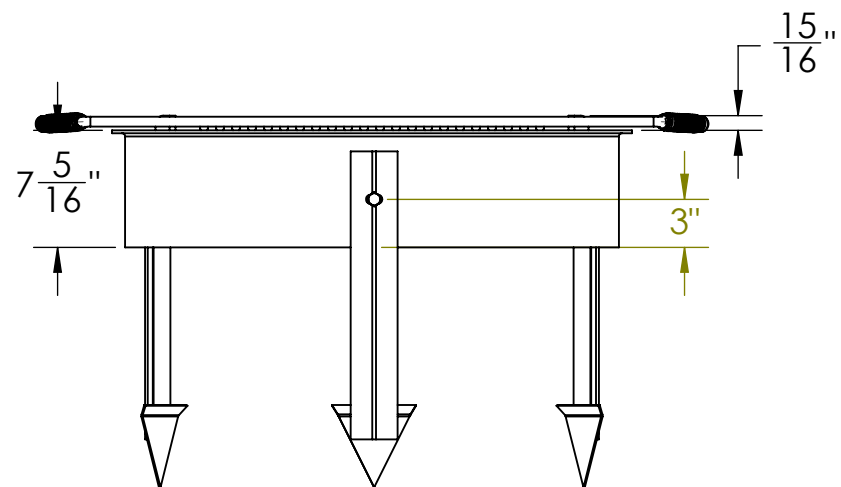
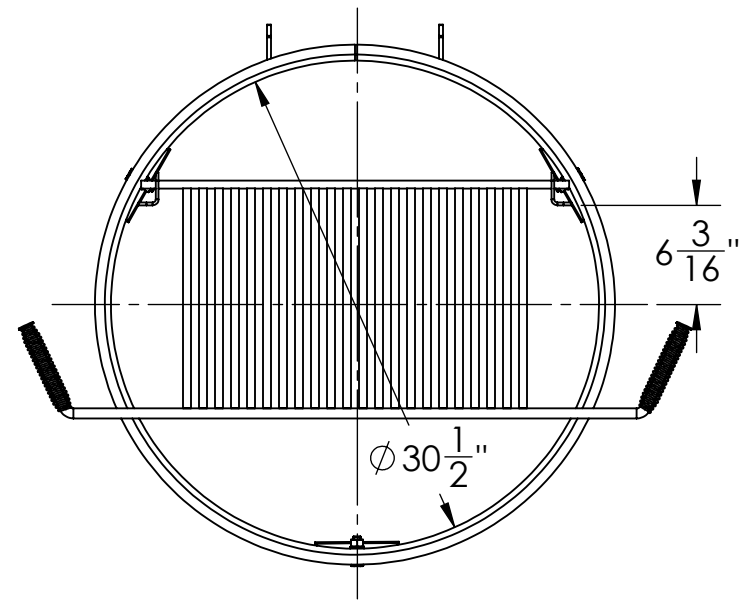

1. Before the assembly mark line on the ground the out side the grill for anchor spade placement and at as same time mark the center line where is bolts mount to grill.
2. Then take a hammer and insert the spade anchor into ground from outside line. Repeat this step with other spade anchors.
3. Place (3) 1/2" x 1 1/2" Hex Bolts into the hole of the Spade anchor and thorough the hole of base grill and other side use lock washer and nuts.

UNIT WGT: 76.5 LBS.

GENERAL NOTES	DIMENSIONS ARE IN INCHES TOLERANCES: LINEAR: ± 1/16 ANGULAR: ± 1°	SHEET SIZE B	SCALE 1:12	REV	
	CONFIDENTIAL DRAWING. INFORMATION IS NOT TO BE COPIED OR DISCLOSED TO OTHERS WITHOUT CONSENT OF KAY INDUSTRIES. SPECIFICATIONS SUBJECT TO CHANGE WITHOUT NOTICE.	DRAWN BY JNB	7/11/2017	DESC:	FIRE RING 7" TILT BACK GRATE & ANCHOR SPADES
		APPROVED		MATL:	
		LAST SAVED	johnb 8/1/2017	PART NO: FR730SAS	