

User manual  
Mode d'emploi

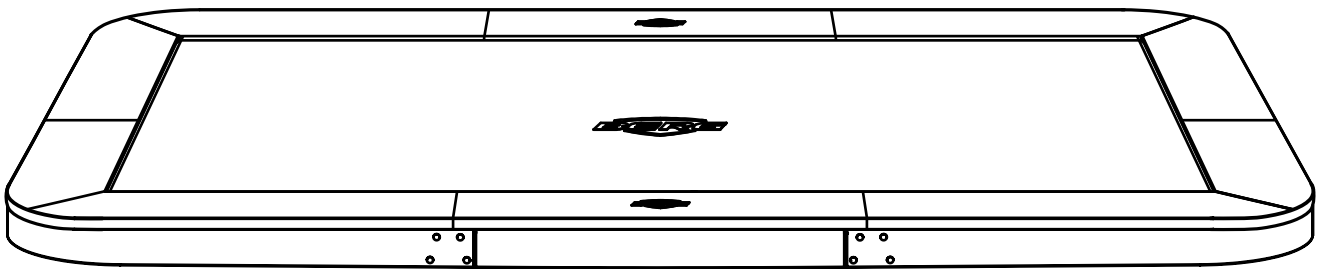

32.38.15.70 - BERG Ultim Champion FlatGround 16ft Green (Box 2)

**! WARNING**

Read the instructions prior to assembling and using this trampoline.  
Consult a physician before beginning any exercise program or strenuous activity.

**! WARNING**

MAXIMUM USER WEIGHT 265 lb (120kg)

**! WARNING**

The contents of this package is not suitable for children under 3 years of age. Contains small parts which may cause choking.  
ADULT ASSEMBLY REQUIRED.

# Index

1. Introduction
2. Product description
3. Warranty
  - 3.1 Warranty period
  - 3.2 Warranty conditions
4. Warnings - General Safety Advice
5. Assembly and installation instructions
6. Care and maintenance instructions
  - 6.1 Disassembly and storage
  - 6.2 Repairs
7. Use instructions
8. Jumping instructions
  - 8.1 Before you start jumping
  - 8.2 Jumping instructions
  - 8.3 Basic jumps
9. Installation instructions

# 1. Introduction

Thank you for choosing BERG as your trampoline purchase of choice. We are confident you will get many years of beneficial use and jumping pleasure.

This manual provides tips about assembly, safe use and jumping instructions for many years of trouble-free use.

Jumping on a trampoline is not dangerous as long as you follow the safety instructions.

Trampoline usage encourages active and healthy play. It has a positive impact on stress, physical condition and blood circulation. Trampoline jumping is for the young and young at heart!

Please check the local ordinances if any restriction are given on trampolines for domestic use, and please check your home insurance coverage on trampolines.

Read the instructions carefully and keep for future reference.

BERG wishes you a fun and active jumping experience!

## 2. Product description

- The frame of the BERG Trampoline is galvanized and powder coated to protect against corrosion.
- To ensure many years of enjoyment, The BERG trampoline is manufactured using high-quality materials only. Proper maintenance and care promotes a long lifespan and injury prevention.

## 3. Warranty

### 3.1 Warranty period

- BERG trampolines are of excellent quality. To provide you with years of carefree fun on our trampolines, BERG offers you a functionality warranty. A functionality warranty is a warranty regarding its functional use. Please consult the table below for the term of this warranty (years).

Trampoline	Champion
Frame	10
Frame ( <i>after product registration</i> )	13 ( <i>10+3</i> )
Padding	2
Jump mat	2
Springs	5
Safety Net	2

- With exception to the 1 year warranty of the BERG weather cover basic, the BERG safety nets and accessories are subject to a warranty period of 2 years. Parts that are susceptible to wear and tear (eg. elastics), the influences of weather (eg. rust and discolouration) and the foam on the BERG safety net tubes are excluded from warranty.

### **3.2 Warranty conditions**

The owner of the product can only claim warranty by presenting the original receipt of purchase. The warranty applies only to material and manufacturing defects related to the BERG product and related parts.

#### **The warranty becomes nul and void if:**

- The product is used improperly and / or negligently.
- The product is not assembled and maintained in accordance with the instruction manual.
- Technical repairs made to the product are not carried out in a professional manner.
- Replacement parts do not correspond to the technical specifications of the product in question or are installed incorrectly.
- Damage caused by the influences of weather such as rust, UV rays or normal wear and tear.
- The product is used for rental purposes or made available for usage by a 3rd party.
- During the warranty period, all material and construction assessed faults will be repaired or replaced by BERG. Repairs handled at no cost is applicable provided the product is still within its warranty period as stated in article 3.1.
- BERG warranty can only be honored if inspected by a BERG authorized dealer.
- BERG warranty can only be honored if the original proof of purchase is rendered to the BERG authorized dealer. Should the owner have re-located or the BERG dealer is no longer operational, BERG can recommend an alternative BERG dealership.
- If the warranty claim is not honored, all costs incurred must be paid by the owner.
- This warranty is not transferable to third parties.
- Not other Warranty beyond that specifically set forth above is authorized by BERG.
- BERG Toys is not responsible or liable for indirect, special or consequential damages arising out of or in connection with the use or performance of the product or other damages with respect to any economic loss, loss of property, loss of revenue or profits, loss of enjoyment or use, cost of removal, installation or other consequential damages.
- Some States do not allow the exclusion or limitation of incidental or consequential damages.
- Accordingly, the above limitation may not apply to you.
- The warranty extended hereunder is in lieu of all other warranties and BERG specifically disclaims any implied warranty of merchantability or fitness for a particular purpose is limited in its scope and duration to the terms set forth herein.
- Some States do not allow limitation on how long an implied warranty lasts.
- Accordingly, the above limitation may not apply to you.
- This warranty gives you specific legal rights. You may also have other rights, which vary from state to state.

#### **Liability Disclaimer**

- While every attempt is made to embody the highest degree of protection in all equipment, we cannot guarantee freedom from injury. The user assumes all risk of injury due to use, assembly, or transportation. All merchandise is sold on this condition, which no representative of the company can waive or change.

# **READ THIS FIRST!!!**



## **WARNING**

**Choking hazard - small parts  
NOT for children under 3 years**

---

While every attempt is made to ensure the highest degree of protection in all equipment, we cannot guarantee freedom from injury.

All merchandise is sold on this condition, which no representative of the company can waive or change.

## 4. Warnings - General Safety Advice

### IMPORTANT - PLEASE READ!

- Ensure the trampoline has been assembled correctly, per the instructions in the manual.
- It is essential that the intended site for this trampoline is completely flat and level. If the ground is not flat and level this will cause movement in the frame and could cause stress on the joined sections.
- This trampoline is only recommended for use by children 6+ years of age.
- Do not exceed the recommended maximum weight limit of:

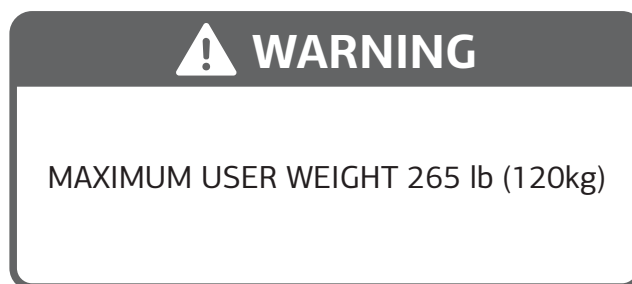

- Do not allow more than one person on the trampoline. Use by more than one person at the same time can result in serious injury.
- Do not attempt or allow somersaults. Landing on the head or neck can cause serious injury, paralysis, or death, even when landing in the middle of the bed.
- Use trampoline only with mature, knowledgeable supervision.
- Not suitable for children under 36 months. Fall Hazard.
- Do not wear glasses or helmets when using the trampoline.
- Do not allow other person to go under, sit, stand, or lie on the trampoline or the frame pads while the trampoline is in use.
- Do not use the trampoline when under the influence of alcohol, drugs or medication which may impair the jumper's judgement and coordination.
- Always wear socks when using the trampoline.
- Always remove jewellery, belt buckles or any other sharp objects before using the trampoline.
- Always jump in the middle of the trampoline bed.
- Always follow the safety warnings stated with your trampoline instructions.
- Always secure the trampoline against unauthorized and unsupervised use.
- Never wear footwear (e.g. shoes) when using the trampoline.
- Children must never be left unattended at any time.
- Before using this product, inspect and replace any worn, defective or missing parts.
- Ensure the trampoline is on level ground with a minimum of 8 feet (2,5m) clear space around the sides, 24 feet (8m) clear height space above and that no obstructions are under the trampoline.
- Always watch for power lines, overhead cabling, and other hazards or obstructions above, around and below the location where you are installing your trampoline. Failure to do so can result in serious injury, death, and property damage for which BERG is not liable.

## **IMPORTANT - PLEASE READ!**

- We recommend using the enclosure of the correct type with the BERG trampolines.
- Any alterations to the construction or materials of this enclosure or deviations from the assembly instructions may result in unforeseeable safety compromises, and the consumer assumes all responsibility for doing so.
- Always ensure the entrance to be fully closed and secure before jumping on the trampoline.
- Always enter and exit the enclosure through the opening only. Use caution to prevent falls and / or accidental strangulation.
- Never attempt to crawl under or climb over the safety net or enter/ exit the enclosure area.
- If the netting material, or any other part of the enclosure becomes damaged, cease using the trampoline immediately until you obtain the necessary replacement parts.
- This safety net and enclosure is only intended to help prevent accidental falls from the trampoline bed / mat, and then only during recommended jumping exercises as described in the BERG trampoline manuals.
- Never attempt to rebound off, swing or hang from the safety net or enclosure poles, nor intentionally attempt to jump into or over the netting, as this may result in serious injury, paralysis or death and severe damage to the enclosure and trampoline. BERG is not responsible for any damage to the trampoline and enclosure or consequential injuries resulting from these practices.
- Never let children take items or toys into the enclosure.
- Always remove jewellery, belt buckles or any other sharp objects before using the enclosure.
- Never wear loose fitting clothing, items, or articles with hooks, loops or any features which can easily become snagged in the safety net.
- Mount and dismount from the trampoline and enclosure with care as injury may result.
- Children should be assisted when entering and exiting the trampoline to reduce risk of falling.
- The frame of your trampoline is made of steel and it will conduct electricity. No electrical equipment (lights, heaters etc.) should be permitted on or around the trampoline under any circumstance.
- Please read and refer to other warnings and use information in the trampoline instructions before use.
- Dispose of all packaging materials safely and per local ordinance.
- It is possible for the trampoline and safety net to be blown away by high wind. If you anticipate high winds, the trampoline and safety net should be moved to a sheltered location or disassembled. BERG is not responsible for any damage resulting from wind or extreme weather.
- We recommend to use the anchor kit which is available at BERG.

## 5. Assembly and installation instructions

- Adequate overhead clearance is essential. A minimum of 24ft (8m) from ground level is recommended. Provide clearance of wires, tree limbs, and other possible hazards.
- Lateral clearance is essential. Place the trampoline away from walls, structures, fences and other play areas. Maintain a clear space on all sides of the trampoline.
- Ensure the BERG trampoline is level after installation. A bubble level is recommended to help qualify.
- Use the trampoline in a well-lit area. Artificial illumination may be required for shady areas.
- Secure the trampoline against unauthorized and unsupervised use.
- Remove any obstructions from beneath the trampoline.
- The owner and supervisors of the trampoline are responsible to make all users aware of practices specified in the use instructions.
- Do not install the trampoline in extreme windy conditions. Wait until wind subsides.
- Gloves are recommended to be worn while installing the BERG trampoline.
- The trampoline should be assembled by an adult in accordance with the assembly instructions. BERG recommends reviewing final assembly prior to usage.
- For installation instructions, refer to page 26.
- For additional trampoline information, contact the manufacturer.
- Install accessories according to the installation manual / guide.
- Location: Find a suitable place for the installation of the trampoline ensuring there are no surrounding obstacles. Verify soil condition and characteristics of designated location to determine installation suitability.
- While digging the hole, soil should be firm to avoid collapsing due to erosion. If necessary, strengthen the sides of the hole or make them smooth to prevent this.
- Should the soil hinder digging a hole, best to choose another location or consult a professional excavation company to provide consultation.
- The dug hole should not accumulate water.
- Verify if a high ground-water level does not contribute to a collection of water in the hole. In addition, verify there is adequate drainage to dispose rain water.
- As per the diagram in the installation manual, use the included tape measure (located in the packaging) to measure and determine the correct diameter, depth and shape of the dug hole.
- Ensure the hole will be dug according to specifications and that the walls are shaped not too steep.
- Deviation from hole specifications can result in unwanted wall collapse and trampoline instability. Follow the diagrams as presented in the installation manual, step by step.
- The legs of the trampoline support the trampoline frame. Ensure the position of the legs are equal in height and rest firmly on the ground. Anchor the legs with the supplied stakes.
- Inspect the hole underneath the trampoline periodically. (Minimum once a year) and if required, take corrective measures. As specified in the installation manual, inspect the hole for:
  - Proper depth.
  - Proper shape.
  - Frame stability and uniformity.
  - Unwanted objects.
- After a rainy period and prior to usage, inspect the trampoline hole. Ensure there is adequate drainage to dispose of rain water.



## 6. Care and maintenance instructions

- Inspect the trampoline before each use and replace any worn, defective, or missing parts. The following conditions could represent potential hazards:
  - 1) Missing, improperly positioned, or insecurely attached frame padding
  - 2) Punctures, frays, tears, or holes worn in the bed or frame padding
  - 3) Deterioration in the stitching or fabric of the bed or frame padding
  - 4) Ruptured springs
  - 5) A bend or broken frame
  - 6) A sagging bed, or
  - 7) Sharp protrusions on the frame or suspension system.
- Ignoring inspections and neglecting maintenance can lead to dangerous situations and unnecessary risks for the user.
- Should the trampoline require movement to another current location (short distance), disassemble the anchors (if any) first prior to relocation. It is recommended the trampoline be lifted via the top rails by 3 adults. Should the trampoline require relocation over a greater distance, it is recommended to disassemble the trampoline parts, re-pack and assemble again at the new location.
- Strong winds and gusts can result in displacement of the trampoline. BERG recommends securing the trampoline by use of anchors or sandbags and removal of the safety net and jump mat.
- In certain areas during the winter period, snow loads and low temperatures can damage the trampoline. BERG recommends storing the jump mat and safety net indoors during these climate conditions.
- Ensure a secure and safe environment when the trampoline is not in use. Protect it against unauthorized use. When a trampoline ladder is used, remove when left unattended. This to ensure no access for children without supervision.
- The use of fertilisers (artificial fertiliser, fertiliser pellets, etc.) within a radius of 2 metres around the BERG trampoline is prohibited. Using such products can cause components to rust.
- The jump mat and padding can be cleaned with a cloth and cold water. NEVER use solvents, dishwashing liquid, detergent or hot water.

### 6.1 Disassembly and storage

- If the trampoline is not used for short periods of time and to avoid jump mat debris caused by fallen leaves and twigs, BERG recommends usage of a BERG Weather Cover. When the trampoline is not used for a longer period of time (e.g. during the winter) BERG recommends storing the trampoline, especially the protective padding, in a dry area to support product longevity.

### 6.2 Repairs

- Contact our BERG authorized dealers for ordering original parts for the BERG trampoline.
- For safety reasons, unless BERG-approved, modifications or changes to the trampoline is prohibited. Repairs must be carried out by a professional. Please consult your BERG dealer.

## 7. Use instructions

### **WARNING:**

- Do not attempt or allow somersaults. Landing on the head or neck can cause serious injury, paralysis, or death, even when landing in the middle of the bed.
- Do not allow more than one person on the trampoline. Use trampoline only with mature, knowledgeable supervision.
- This trampoline is only recommended for use by children over 6 years of age.
- Inspect the trampoline before each use. Make sure the frame padding is correctly and securely positioned. Replace any worn, defective, or missing parts.
- Make sure the frame padding is correctly and securely positioned.
- Climb on and off the trampoline. It is a dangerous practice to jump from the trampoline to the floor or ground when dismounting, or to jump onto the trampoline when mounting. Do not use the trampoline as a springboard to other objects.
- Stop bounce by flexing knees as feet come in contact with the trampoline bed. Learn this skill before attempting others.
- Learn fundamental bounces and body positions thoroughly before trying more advanced skills. A variety of trampoline activities can be carried out by performing the basic fundamentals in various series and combinations, performing one fundamental after another, with or without feet bounces between them.
- Avoid bouncing too high. Stay low until bounce control and repeated landing in the center of the trampoline can be accomplished. Control is more important than height.
- While keeping the head erect, focus eyes on the trampoline toward the perimeter. This will help control bounce.
- Avoid bouncing when tired. Keep turns short.
- Properly secure the trampoline when not in use. Protect it against unauthorized use. If a trampoline ladder is used, the supervisor should remove it from the trampoline when leaving the area to prevent unsupervised access by children under 6 years.
- Do not use or stand near the trampoline in windy or gusty conditions. A trampoline can become airborne when exposed to sustained wind or gusting wind conditions. This can result in serious injury, paralysis, or death, as well as property damage. To reduce these risks, disassemble the trampoline and enclosure and store them until weather conditions improve. Anchoring a trampoline frame may prevent the trampoline from moving as a result of the wind, but even anchored trampolines can become airborne or damaged. Consult a qualified contractor to determine what type of anchor works best in your location.
- Keep objects away which could interfere with the performer. Maintain a clear area around the trampoline.
- Do not use the trampoline while under the influence of alcohol or drugs.
- For additional information concerning the trampoline equipment, contact the manufacturer.
- For additional information concerning skill training, contact a certified trampoline instructor.
- Bounce only when the surface of the bed is dry. Wind or air movement should be calm to gentle. The trampoline must not be used in gusty or severe winds.
- Read all instructions before using the trampoline. Warnings and instructions for the care, maintenance, and use of this trampoline are included to promote safe, enjoyable use of this equipment.
- The BERG trampoline is for outdoor use only.
- Jump without shoes.
- Empty pockets and hands before jumping.
- Always jump in the middle of the jump mat.
- Do not eat while jumping.
- Do not use the jump mat when it is wet.
- Do not use in strong wind conditions and secure the trampoline.

## 8. Jumping instructions

### 8.1 Before you start jumping

- Objects, animals or persons are prohibited underneath the BERG trampoline.
- Only use the BERG trampoline when it is clean and dry.
- Objects and other obstacles that can interfere with jumping should be prohibited from the jumping area.

### 8.2 Jumping instructions

- Do not enter or leave the trampoline by jumping.
- Proper movement while using the BERG trampoline requires good posture. Correct posture and balance are achieved by tensing the muscles.
- Good posture ensures safe usage of the BERG trampoline. When jumping, the body is exposed to shocks that require correct absorption. By tensing your muscles, you obtain better control over your balance and this results in more jumping resilience. In contrast, a more relaxed posture leads to loss of energy and jumping resilience. Begin with the basic jumps and jumping positions and only increase complexity when mastered. To come to a stop position when jumping, bend knees when your feet touch the mat.
- Always jump in the middle of the mat. Avoid jumping on mat edge and trampoline padding.
- To come to a stop position when jumping, bend and flex knees when your feet touch the mat. Learn this skill before attempting others.
- Learn fundamental bounces and body positions thoroughly before trying more advanced skills. A variety of jumping techniques can be carried out solo or in series and/or combinations between bounces.
- Avoid bouncing too high. First obtain jumping control with proper landing position in middle of mat. From a safety perspective, control is more important than height.
- To ensure and maintain control while jumping, ensure jumping posture is straight, head is in upright position and eyes are focused on the jump mat.
- Movements that cause considerable friction (such as a “sliding” action) on the printing on the jumping mat or the padding are not recommended. Heavy friction when sliding over the printing on the jumping mat or the padding could result in the ink rubbing off onto skin or clothing. It may be difficult to remove the ink from clothing. The ink meets the stringent chemical requirements imposed on toy products, therefore contact with the skin or ingestion of this ink has no harmful effects on human health.

### 8.3 Some basic jumps

#### *Basic bounce*

Upright position, head held in upright position. Eyes focused on the jump mat. While jumping upwards, swing arms forward and in circular motion and point your toes downwards. Keep feet positioned together, toes pointed downwards when returning back to the jump mat. When landing on the jump mat, keep your feet approximately 16 inches (40cm) apart.

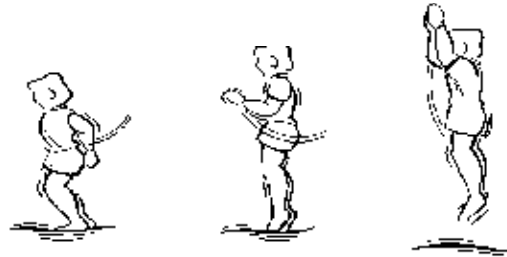

#### *Hands and knees bounce*

Commence with basic bounce. Keep eyes focused on jump mat. Swing arms forward and in circular motion. Land on hands and knees. Push off with hands and return to upright position.

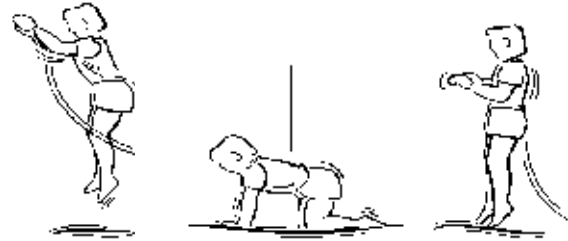

#### *Seat drop*

Commence with basic bounce. Keep eyes focused on jump mat. Land in sitting position. Place hands next to hips on jump mat when in sitting position. Push off with hands en return to upright position.



#### *Front bounce*

Commence with basic bounce and land on your stomach. Keep head straight. Keep arms extended forward on the jump mat. Push off with hands and return to upright position.



#### *Back drop*

Commence with basic bounce and land on your back. Keep chin pressed against your chest during landing. Kick forward and up with legs when returning to a standing position.



# BERG



## PRODUCT REGISTRATION

**Would you like free supplementary guarantee?\***







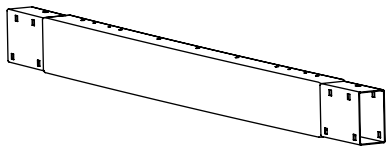

Don't forget to register your product online immediately!  
Go to **[www.bergtoys.com/registration](http://www.bergtoys.com/registration)**.

This product registration entitles you to 3 years extended warranty on the frame of your go-kart or trampoline. This extended warranty is in addition to the standard warranty on the frame that you receive.

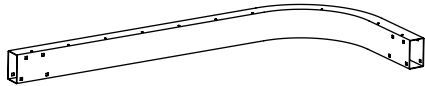
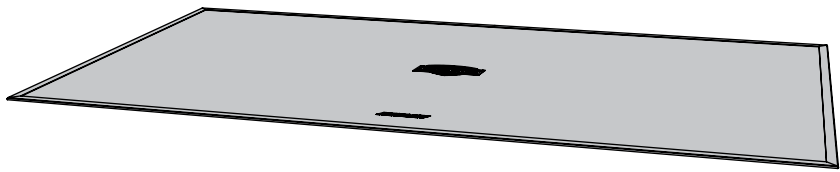
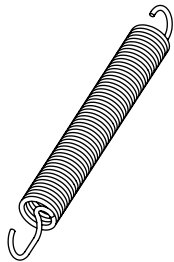
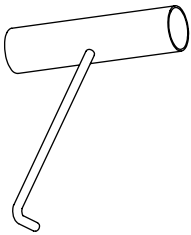
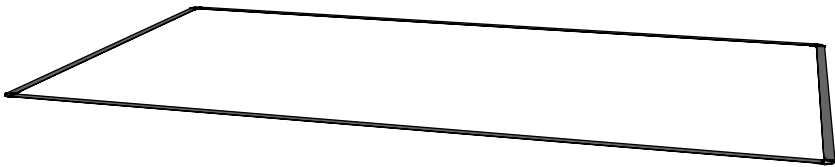
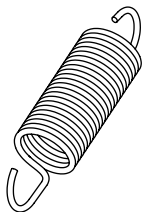
\*For the conditions, please visit [www.bergtoys.com/registration](http://www.bergtoys.com/registration)

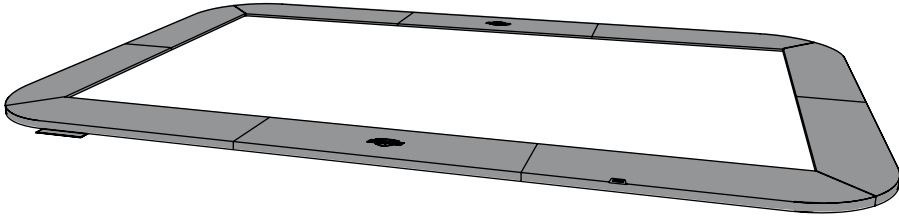
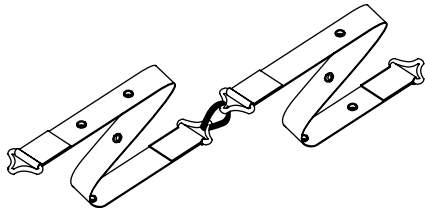

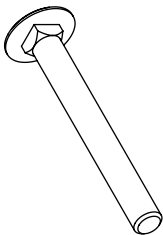
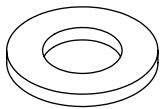
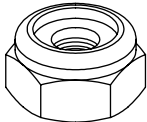
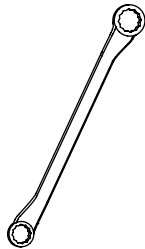
**[www.bergtoys.com/registration](http://www.bergtoys.com/registration)**

 <p>1 4x</p>	 <p>2 2x</p>	 <p>3 2x</p>			
 <p>4 1x</p>	 <p>5 104x</p>	 <p>6 1x</p>			
 <p>7 1x</p>	 <p>8 4x</p>	 <p>9 8x</p>			
 <p>10 1x</p>	 <p>11 1x</p>				
 <p>12 2x</p>	 <p>13 32x</p>	 <p>14 32x</p>	 <p>15 32x</p>	 <p>16 1x</p>	 <p>17 1x</p>

1

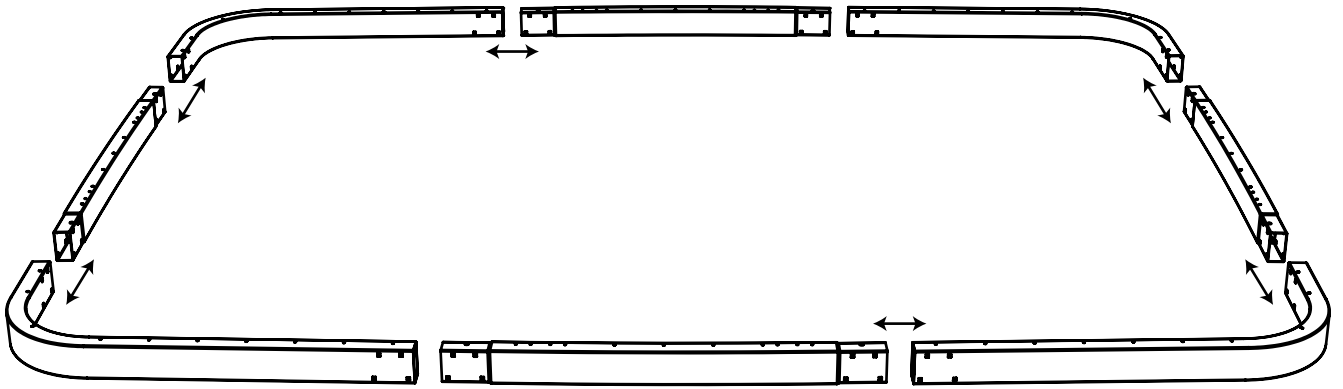

+ Safety Net

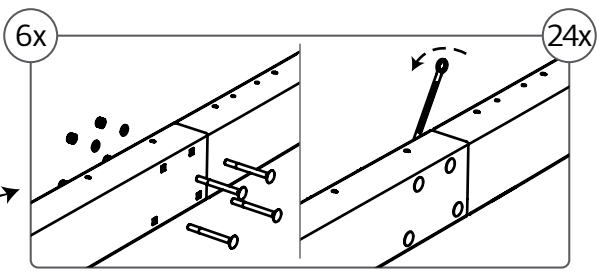
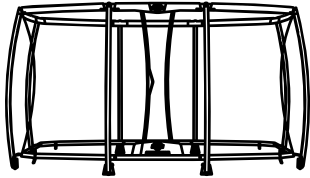

+ AeroWall

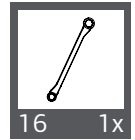
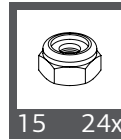
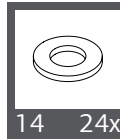
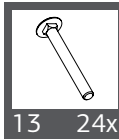
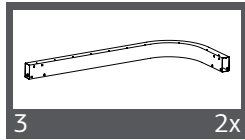
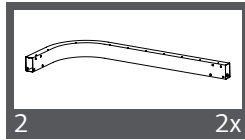
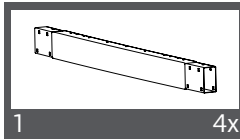
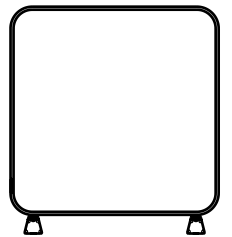

2

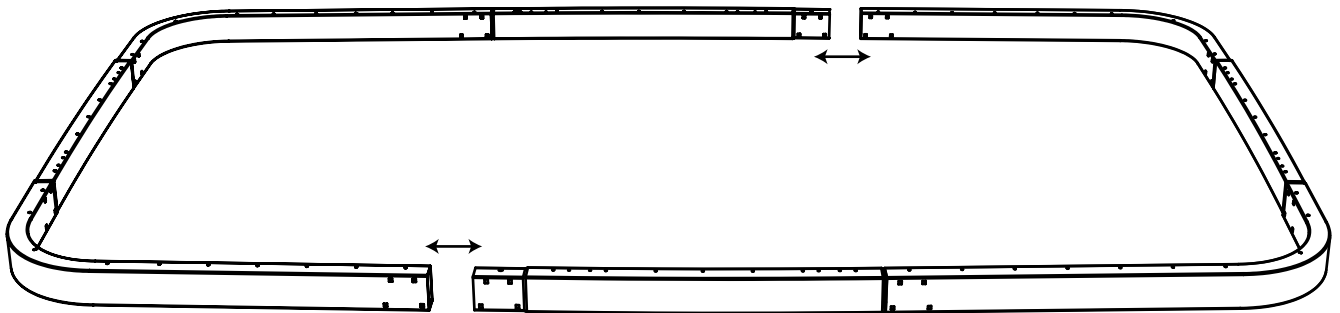

+ Safety Net

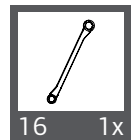
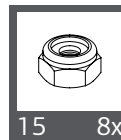
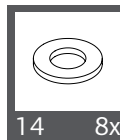
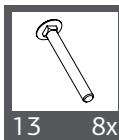
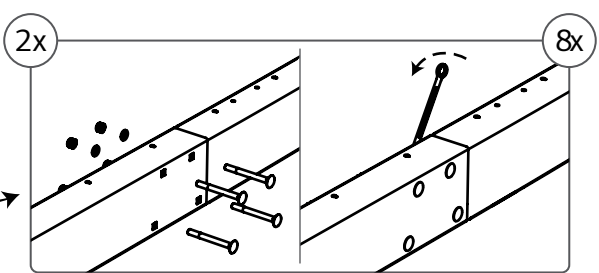
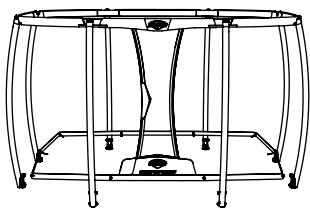

3

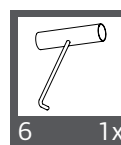
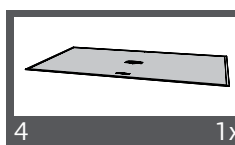
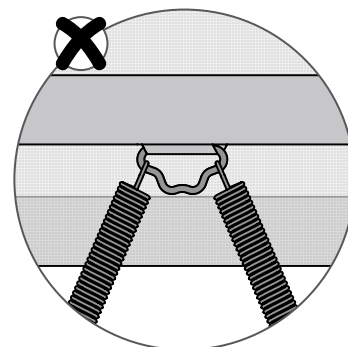
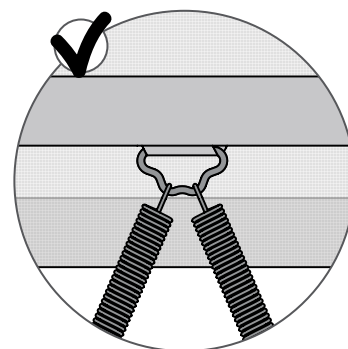
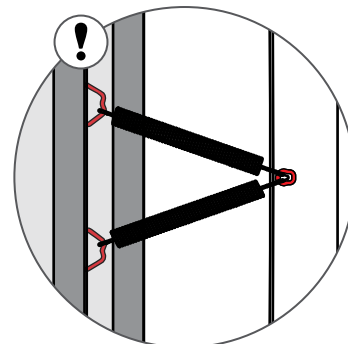
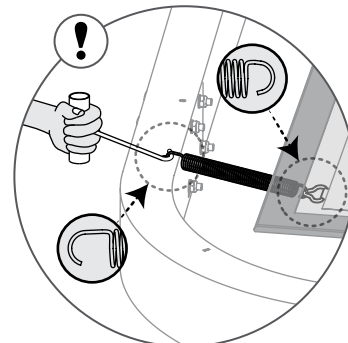
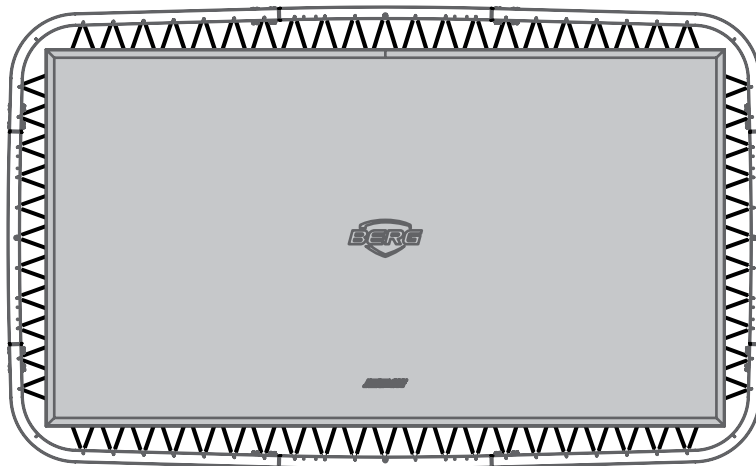
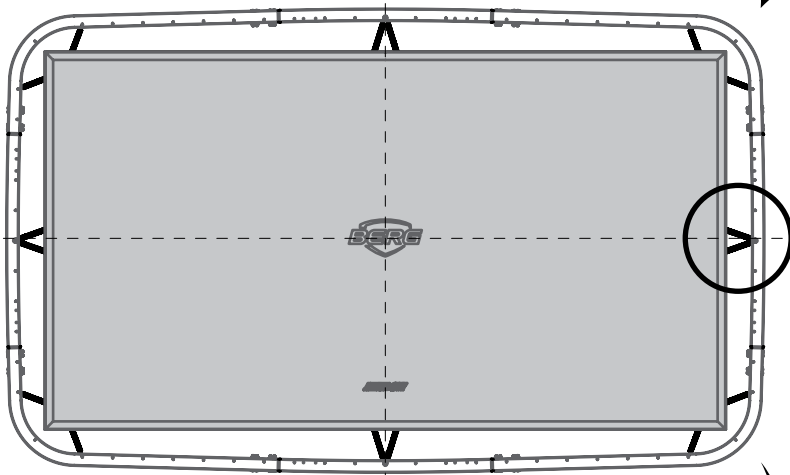
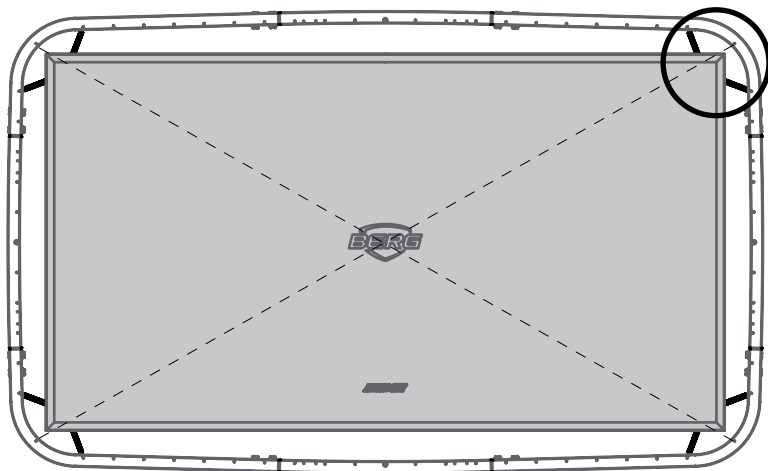



4

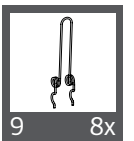
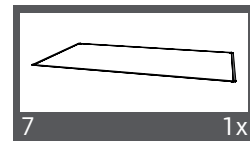
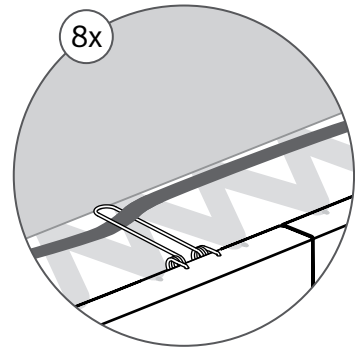
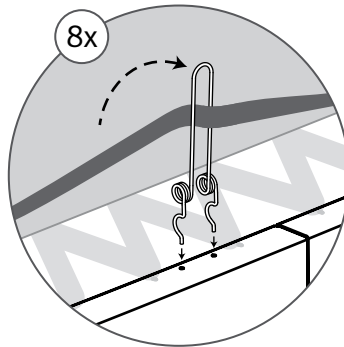
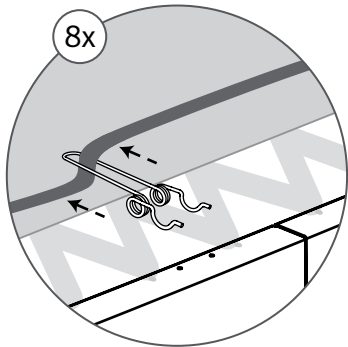
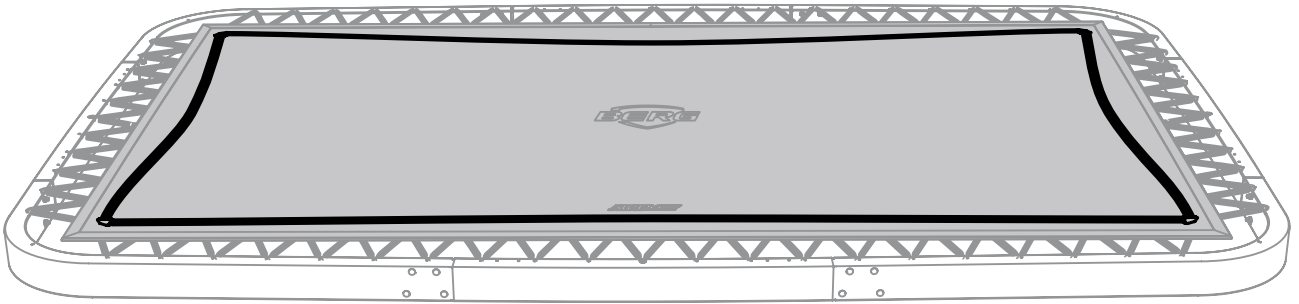

5

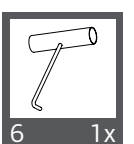
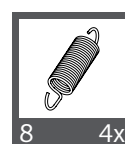
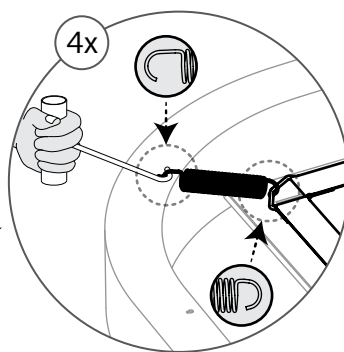
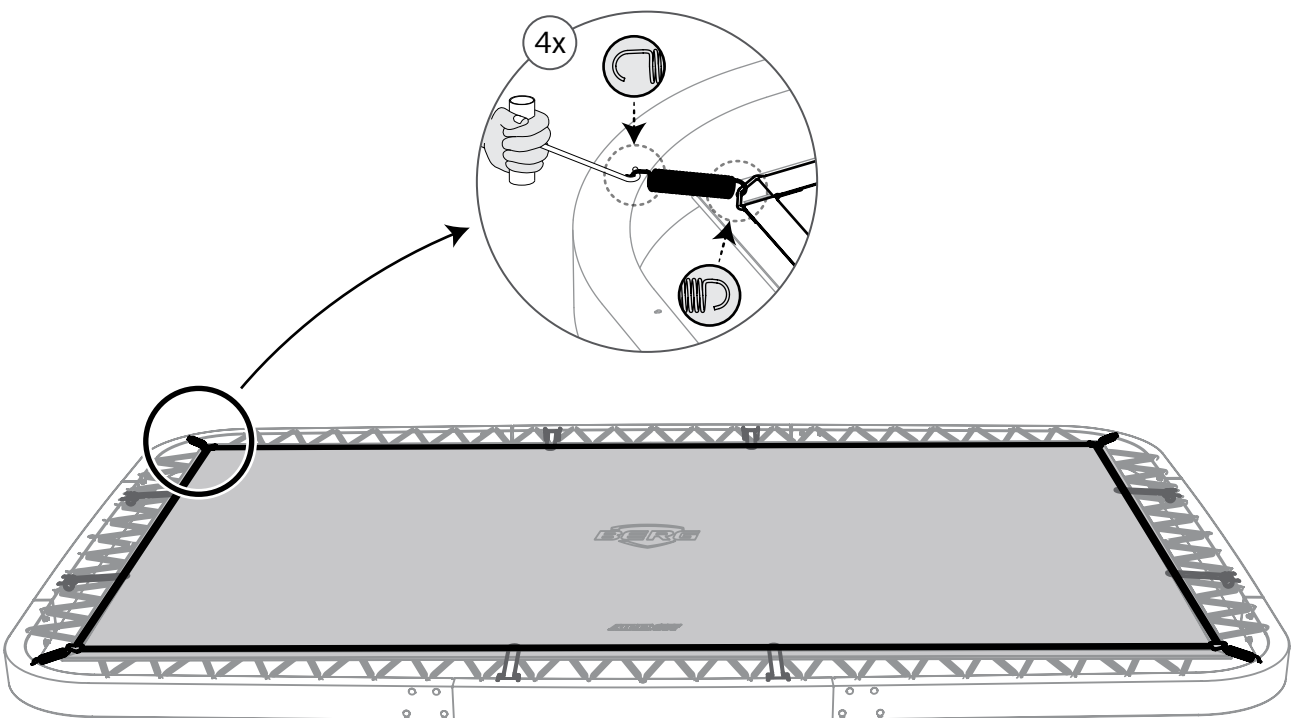

6

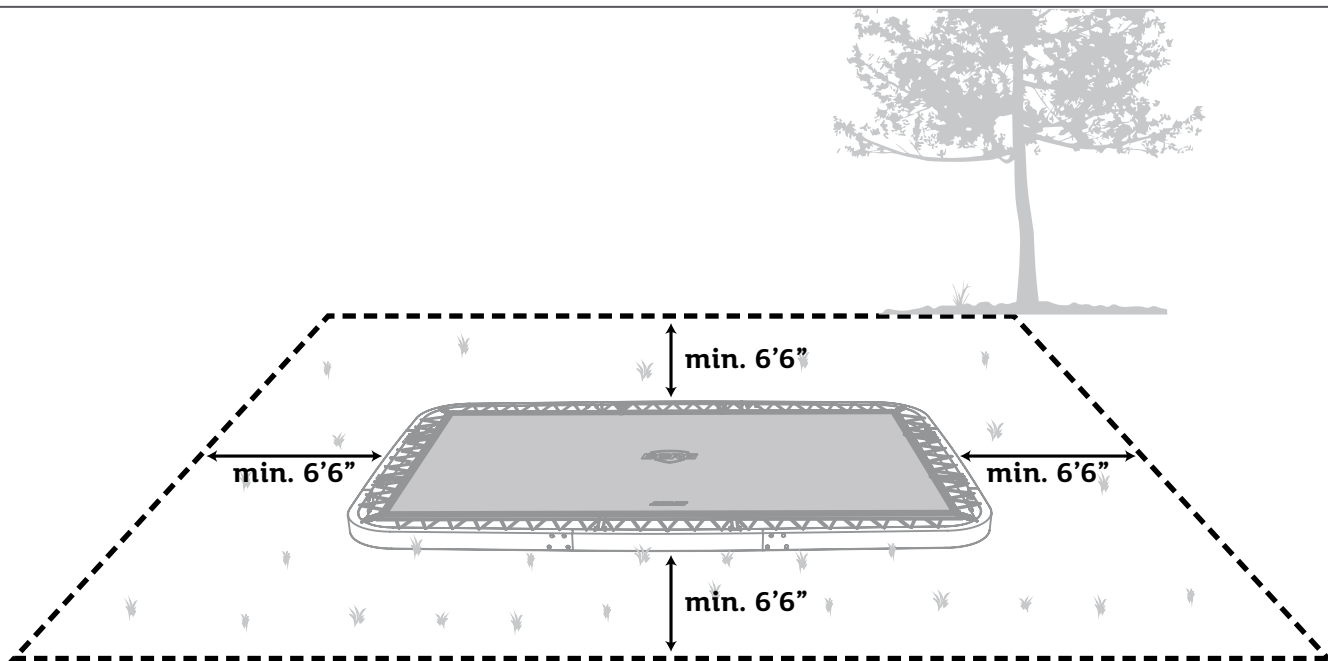

7

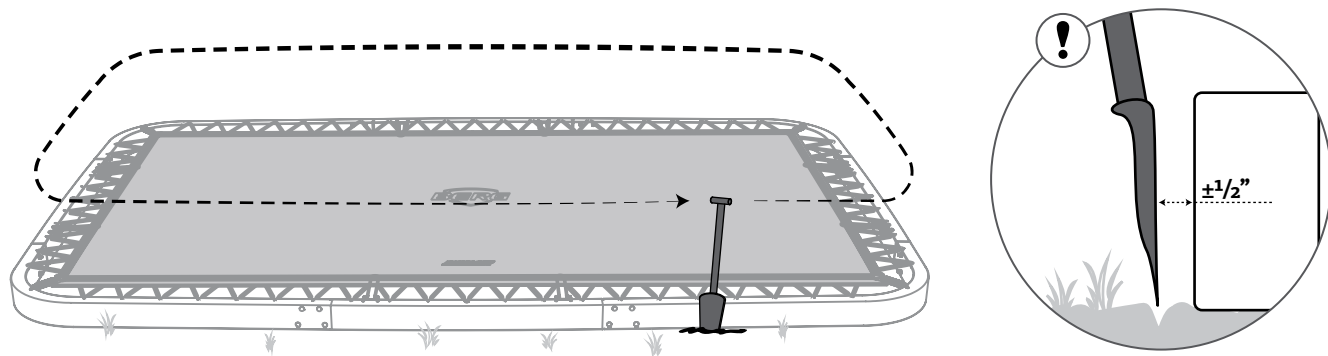

8

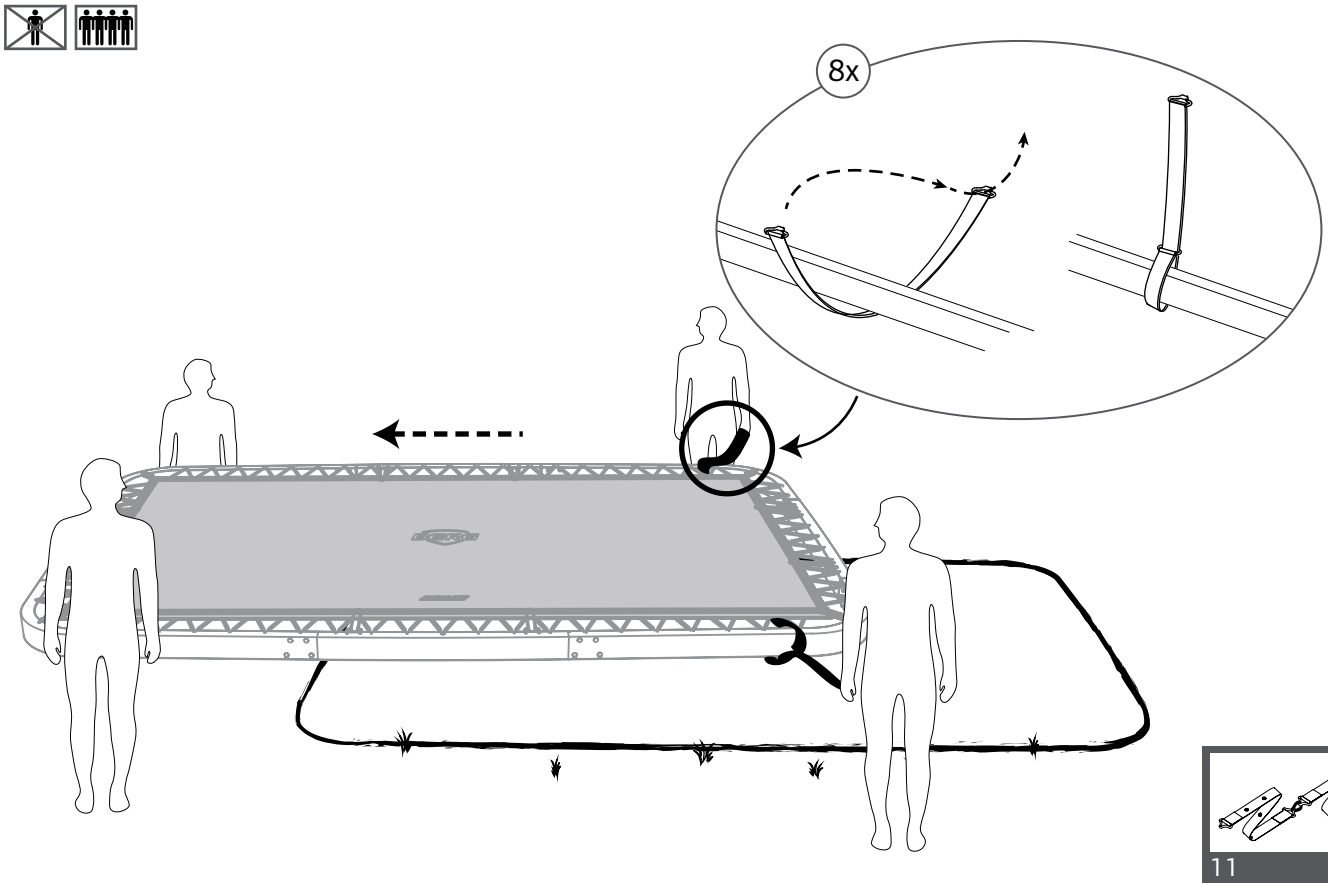

9

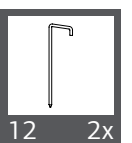
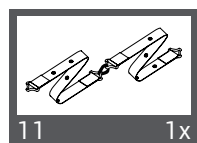
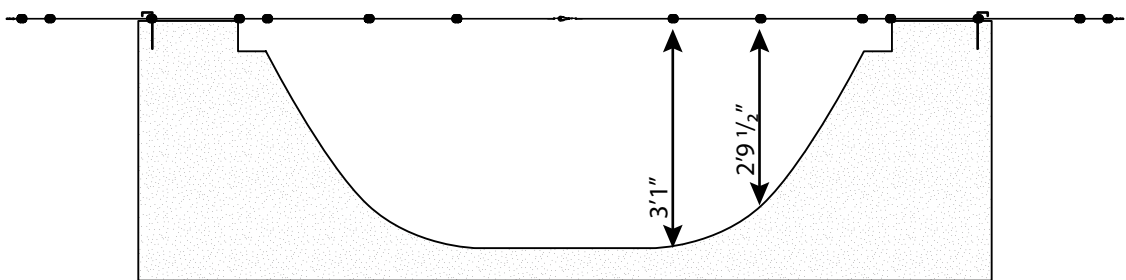
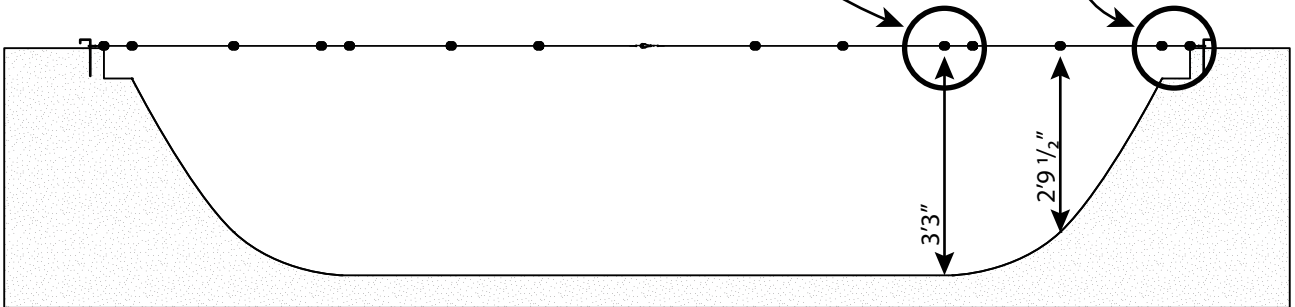
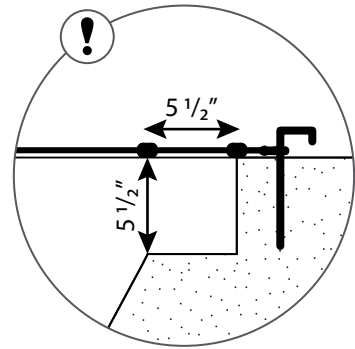
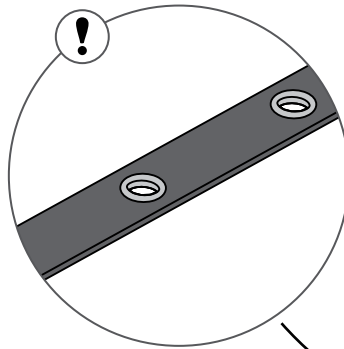
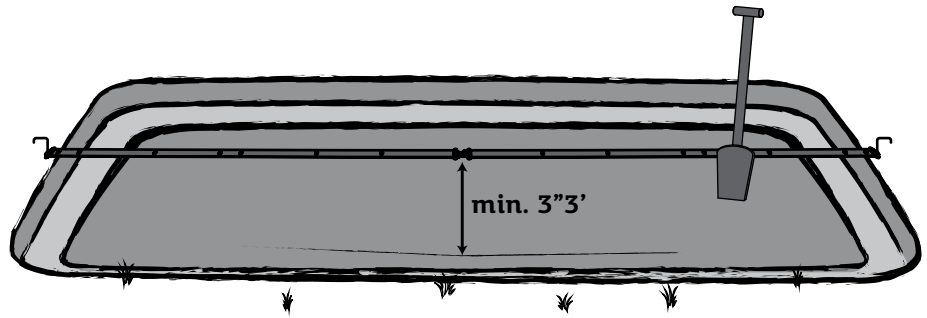
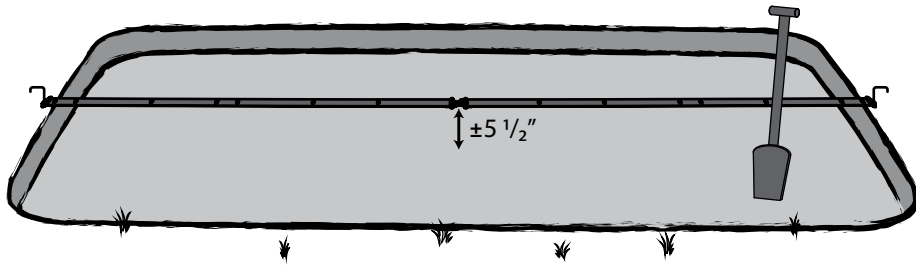

10



Hole depth / Profondeur du trou



Min. 3'3"

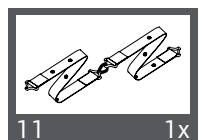
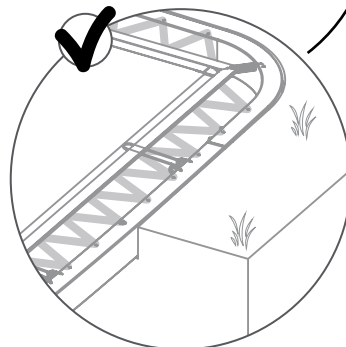
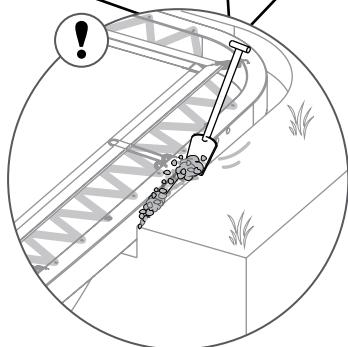
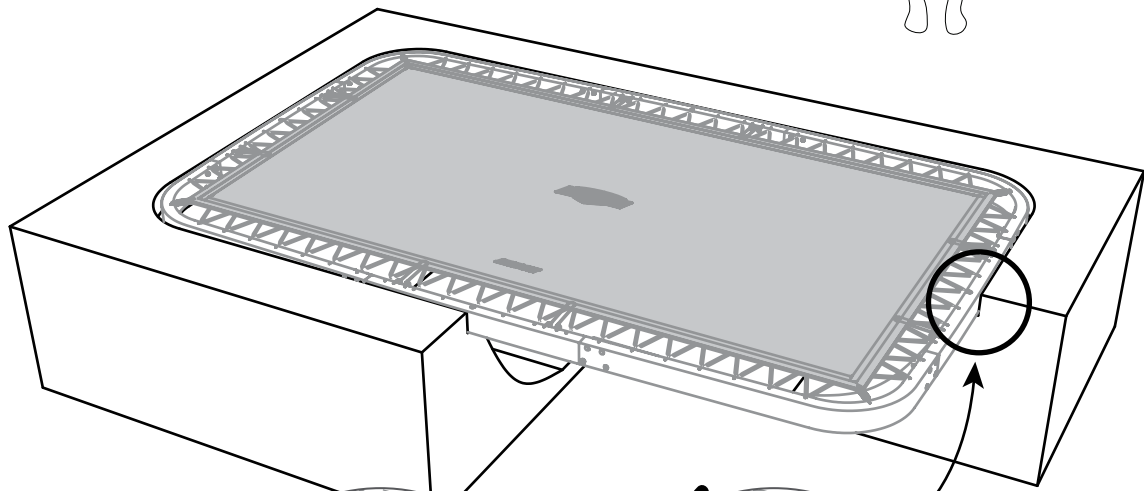
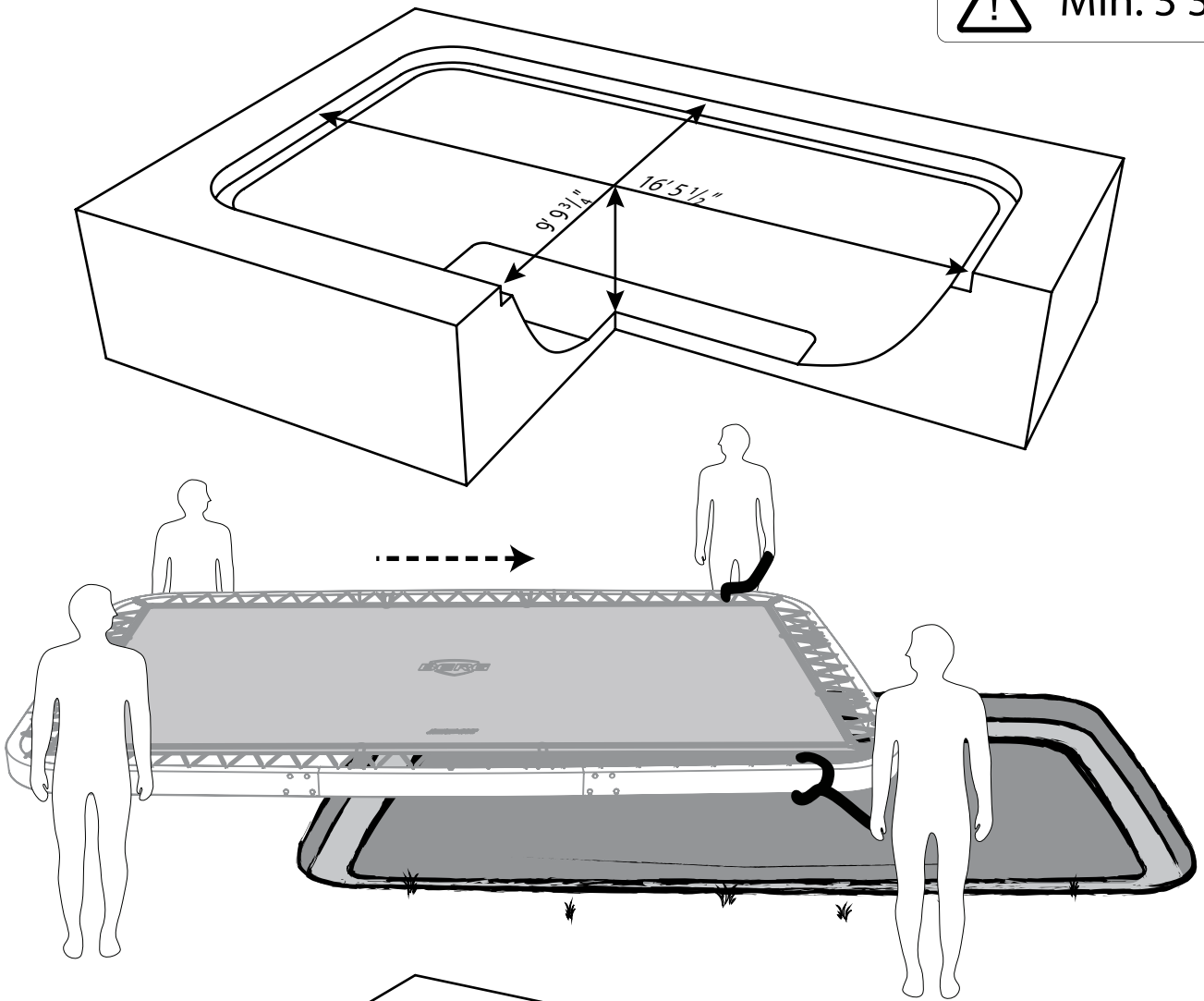

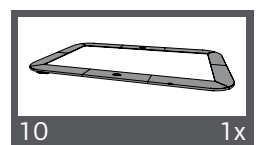
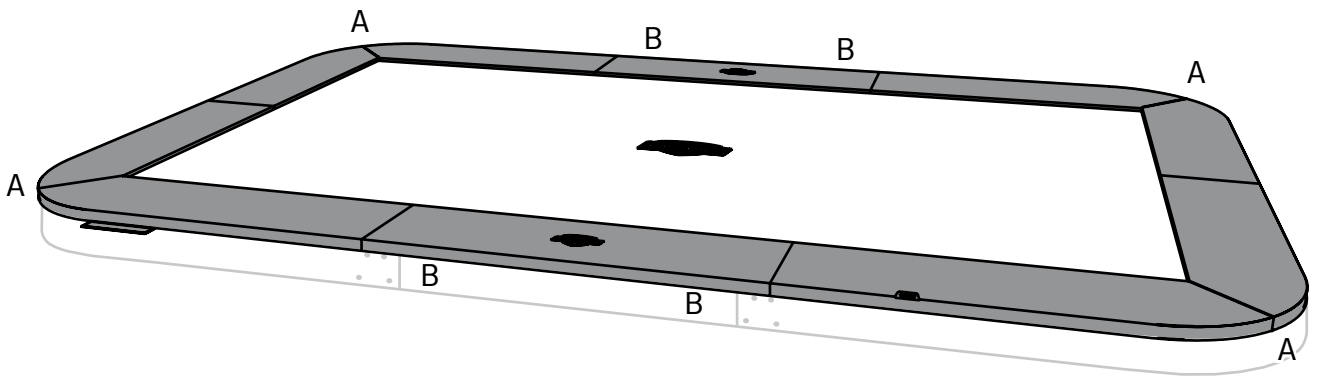
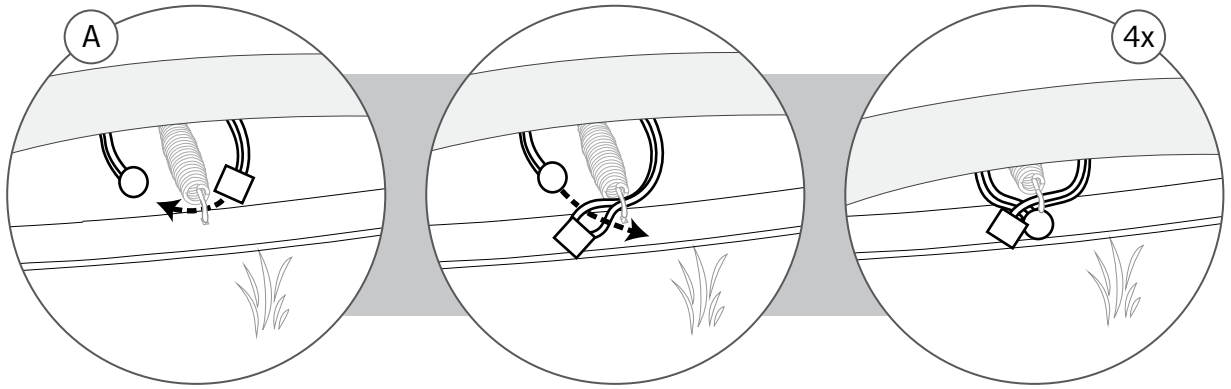

12 10x

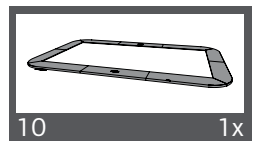
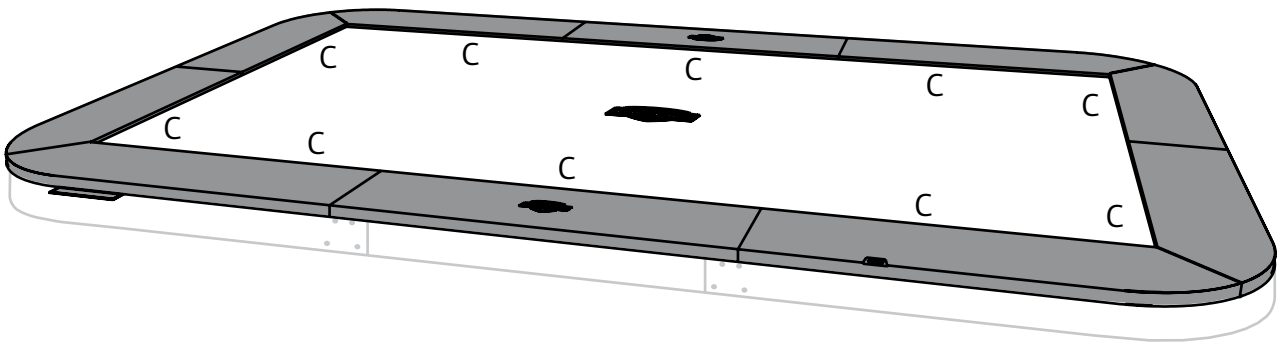
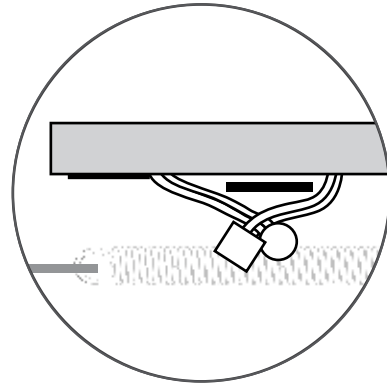
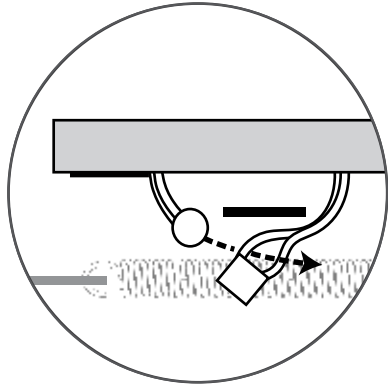
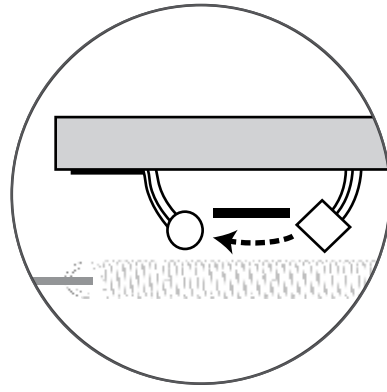
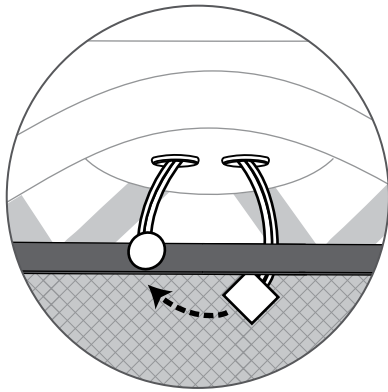

Place the sign containing use instructions in a highly visible and safe location.  
The sign shall be placed such that that it will be readily visible to the intended viewer.

Placer une vignette contenant les instructions d'utilisation à un endroit nettement visible et sûr.  
La vignette doit être visible, résistante et apparaître en permanence.